HK-6D-U402 Operation manual of motion control system of six axis touch screen screw machine

V2.2



Shenzhen HengKong Technology Co.,Ltd

**Address: Floor 4, Building D, Phase II, Huafeng International Robotics Industrial
Park, Guxing Community, Xixiang Street, Baoan District, Shenzhen.**

Tel: 0755-27726892 Fax: 0755-23017249

Catalogues

Chapter 1	Overview	1
1.1	Hardware	1
1.2	Software	2
1.3	Product configuration list	3
1.4	Main board floor mounting dimensions	3
1.5	System interface and wiring diagram	4
1.6	HMI upgrade instructions	8
Chapter 2	Main interface and key description	9
2.1	Main interface description	9
2.2	MiniBOX Teaching Box	9
Chapter 3	Group parameters	12
3.1	Empty point process setting	12
3.2	Automatic reset setting	13
3.3	Aging mode parameter setting	13
3.4	Batch parameter setting	14
3.6	Edit group parameters	17
3.6.1	Processing parameter interface	17
3.6.2	Supply Parameters Screen	19
3.6.3	Transit Parameters screen	22
3.6.4	Screw removal parameter interface	23
3.7	Group Supply Position	24
3.8	Group parameter copying	24
3.9	Cross-machine replication of group parameters	25
3.10	Clear processing information	25
Chapter 4	Teaching Programming	26
4.1	Teach-In-Interface	26
4.2	Axis Motion Button	27
4.3	Function button	27
4.4	More Functions Button	29

4.4.1	Inclined Array	30
4.4.2	Flat arrays	31
4.4.3	Labeling	32
4.4.4	Array Expansion	32
4.4.5	Output Programming	32
4.4.6	Input Programming	33
4.4.7	program jump	33
4.4.8	Delay	34
4.4.9	Back to the original point.	34
4.4.10	Single axis motion	35
4.4.11	Empty point	35
4.4.12	Midway adjustments	35
Chapter 5	Files	36
Chapter 6	IO Monitor	38
Chapter 7	System parameters	40
7.1	Axis parameter setting	40
7.2	Batch parameter setting	41
7.3	Machine Structure Setting	41
7.4	Workpiece Inspection Function Setting	44
7.5	Product Clamping Function Setting	45
7.6	Product Removal Function Setting	46
7.7	Speed parameter setting	47
7.8	Acceleration parameter setting	48
7.9	Machine button setting	49
7.10	Grille & Tri-colour Light Setting	50
7.11	Home function setting	51
7.12	Other Function Setting	53
7.12.1	Drive-related settings	53
7.12.2	Restore Factory Setting	55
7.12.3	Initialise processing parameters	55

7.12.4	Board application upgrade	56
7.12.5	File Switching Setting	57
7.12.6	Machine Name Editor	58
7.12.7	Password & HMI Management	59



Chapter 1 Overview

HK-6D-U402 automatic screw machine control system has 6 motor control axes, which can support 6-axis use mode and 4-axis use mode. The 6-axis use mode includes: dual three-axis platform independent structure, dual three-axis gantry independent structure, single-platform single gantry hybrid structure and front and rear dual-platform 6-axis collaborative structure; four-axis use of dual-platform four-axis structure. hk-6d-U402 supports external 800 X 480 pixels of true colour 7-inch LCD touch screen, with simple interaction and fast programming features such as feature-rich. At the same time, the addition of Mini handheld programmer makes teaching programming more convenient and easy to use. The main board and the touch screen using industrial field bus communication connection, higher rate, stronger anti-interference. In the use of multiple devices can be used to copy the device parameters and processing files, in order to improve the efficiency of equipment debugging and mass production. hk-6d-U402 adopts ARM + FPGA control scheme, has a strong computing power, the speed refresh time is very small, the motion control acceleration and deceleration performance is superior. hk-6d-U402 motion control motherboard has a 16M storage space, can store 100 processing files, each file can store 900 files, each file can be stored. files, each file can store 900 machining programming points.

1.1 Hardware

1. Motor axis output: 6-axis output.
2. Acceleration and deceleration characteristics: Independent setting of acceleration and deceleration for each axis.
3. Pulse Output Frequency: 1MHz pulse output frequency for single axis.
4. Home input: Each motor axis with independent dedicated home input, hardware resources corresponding to the input port 1-6.
5. Programmable inputs and outputs: 32 independent dedicated programmable inputs, all of which are isolated by optocouplers; 24 independent dedicated outputs, each of which can output current up to 500mA.
6. CAN bus, RS-232, RS-485 interface, can be customised for customers with special needs.

-
7. U disk read and write function: the use of FAT32 file system, no longer subject to greater than 2G capacity of the U disk can not be formatted into FAT format restrictions.
 8. Storage space: motherboard 16MB, can store 100 processing files, each file 900 programming points.
 9. touch screen screen: 800 x 480 pixels, true colour 7-inch LCD touch screen, so that the operation menu interface and boot screen of the content is more rich.
 10. Operating voltage: DC 24V, current 5A.
 11. Working environment: temperature 0 °C - 45 °C, humidity 40% - 80%.

1.2 Software

1. 1. 20 times of "Undo" and "Redo" are available for editing the programming point, which effectively prevents misoperation.
2. 3. Matching group machining parameter mode for programming point, so that each programming point can have a completely different machining process.
3. 3. Abundant and powerful group parameter process: processing speed parameters, running speed parameters, processing time parameters, safety height parameters, electric batch parameters, material supply parameters, vacuum detection parameters, removal of screws process parameters, empty lock process parameters, various types of alarm function settings and adjustments, and other parameters.
4. 4. 256 groups of different groups of parameter process settings are supported by a single side of the machine, and a total of 512 groups of process parameters are supported by a double machine.
5. 5. intelligent electric batch torque, speed, position real-time monitoring. Intelligent electric batch support: research control, Wade, Kuroshio, etc..
6. 6. Servo drive alarm support.
7. 7. Support Minibox handheld manual teaching mode and drag and drop teaching mode.
8. 8. Powerful mechanical structure support:
9. Dual machine independent structure: dual three-axis platform type, dual three-axis gantry type, single platform single gantry hybrid structure.
10. Four-axis non-independent structure: universal dual-platform four-axis structure.
11. Six-axis non-independent structure: front and rear dual-platform collaborative six-axis structure.
12. Equipped with: Sequence Priority Mode and Efficiency Priority Mode.
13. 9. When returning to the home position, each axis returns to the home position, X1, Y1, Z1, X2, Y2, Z2, six axes will perform the home position capturing action at the same time.
14. Translated with DeepL.com (free version).

1.3 Product configuration list

Item name	quantity	Model / specification	remarks
Main board	1	HK-6D-U402	
WEINVIEW touch screen	1	HK-HMI-070800480R01	
MinBOX Teaching box	1	/	
MinBOX Teaching box	1	/	
connecting line			
Terminal block	1	/	

1.4 Main board floor mounting dimensions

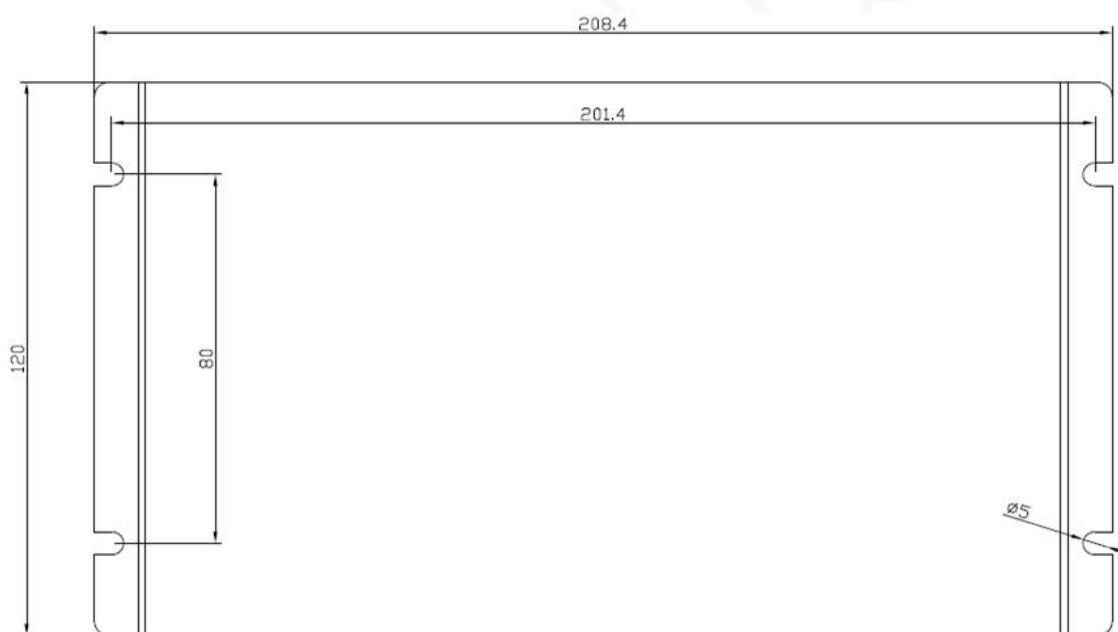

HK-6D-U402 Dimension drawing

1.5 System interface and wiring diagram

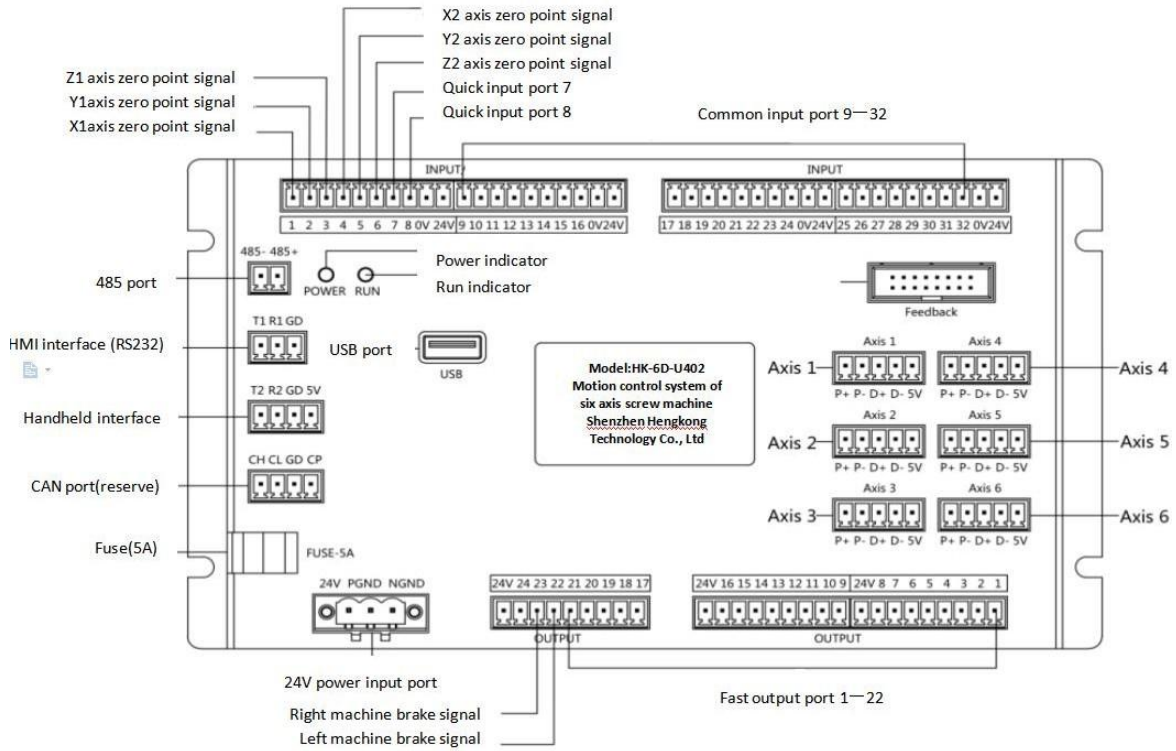

HK-6D-U402 Interface Schematic

Special interface definition and description.

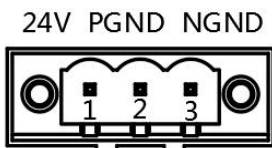

Power Input

Power Input Pin Definition and Description			
No.	Name	Function	Instruction
1	24V	24V power input	Connect 24V switching power supply VCC (DC V+)
2	PGND	0V	Connect 24V switching power supply 0V (DC V-)
3	NGND	NGND	Connecting 24V power supply FG(\perp)

T1 R1 GD

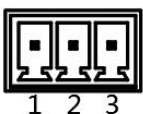

RS232/HMI interface

RS232/HMI Interface Pin Definition and Description			
No.	Name	Function	Instruction
1	T1	Data Transmitter	Connecting the configuration screen COM1 (232) pin 2
2	R1	Data Transmitter	Connecting the configuration screen COM1 (232) pin 3
3	GND	GND	Don't accept

Input definition and description:

Input Pin definition and function description			
No.	Neme	Function	Wiring description
1	Input Pin1	X1 Axis Origin	X1 axis origin sensor signal pin out (black line)
2	Input Pin2	Y1Axis Origin	Y1axis origin sensor signal pin out (black line)
3	Input Pin3	Z1Axis Origin	Z1axis origin sensor signal pin out (black line)
4	Input Pin4	X2Axis Origin	X2axis origin sensor signal pin out (black line)
5	Input Pin5	Y2Axis Origin	Y2axis origin sensor signal pin out (black line)
6	Input Pin6	Z2Axis Origin	Z2axis origin sensor signal pin out (black line)
7-8	Input Pin7-8	fast input port	It can connect button, electric batch locked rotor signal, needle alignment signal, etc. (support capture)
9-32	Input Pin117-32	Common input port	It can receive input signals such as buttons and sensors (capture is not supported)

Typical wiring of input port:

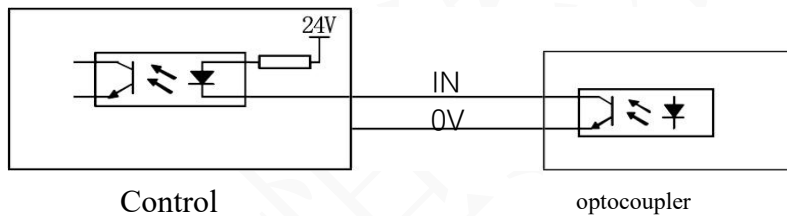

Typical wiring of input port: switch signal wiring method

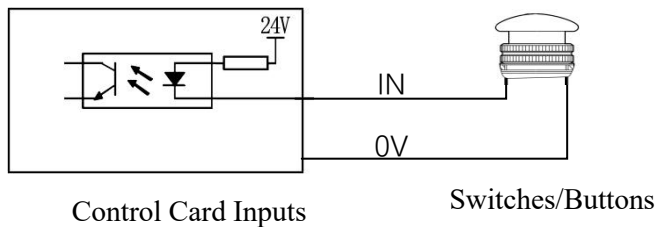

Typical Input Wiring: Relay Transit Mode

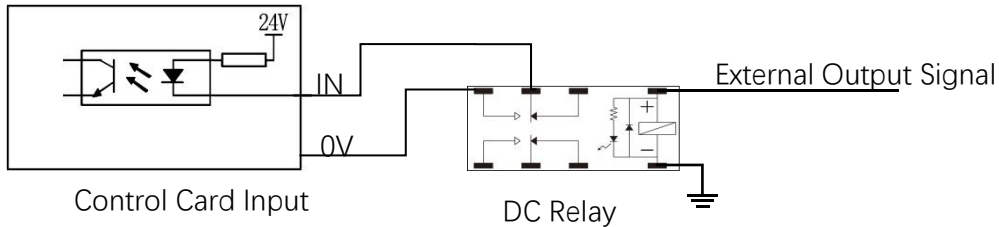

Output port definitions and descriptions:

Output Pin Definition and Function			
NO.	Name	Functionality	Wiring Description
1-22	Outputs 1-22	Rapid output port	Optocoupler output, can be used to control peripheral devices
23	Left machine brake signal	Brake control signal	Default is brake control signal, can be configured as normal output port
24	Right machine brake signal	Brake control signal	Default is brake control signal, can be configured as normal output port

Typical Output Wiring: Relay Transit Mode

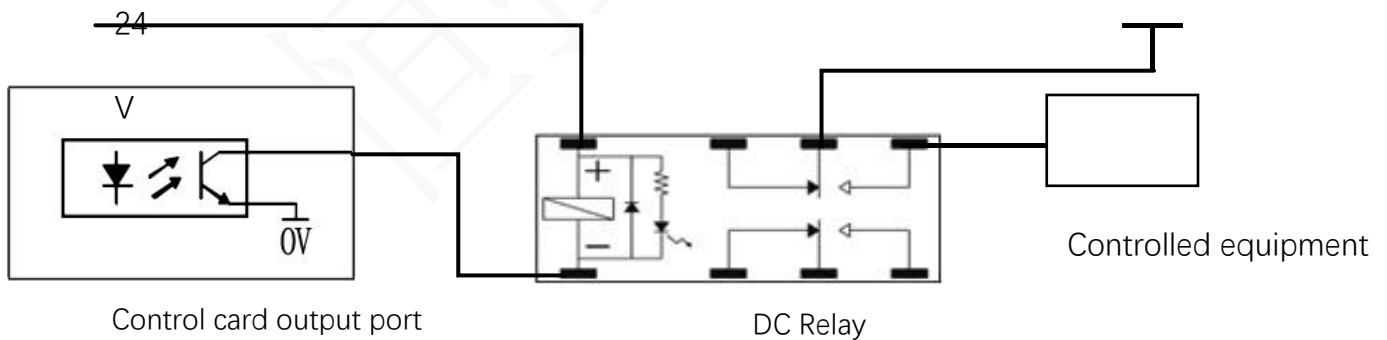

Brake wiring diagram:

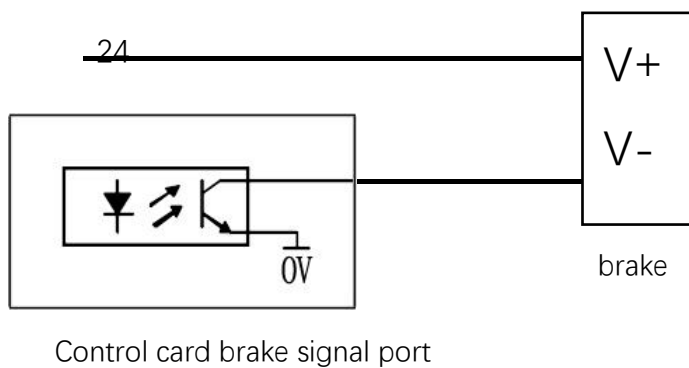

Motor port definition and description:

Motor Signal Pin Definition and Function Description			
No.	Neme	Function	Instruction
1	P+	Pulse signal +	Positive motor pulse signal, differential signal type (5 V voltage domain)
2	P-	Pulse signal -	Motor pulse negative signal, differential signal type (5 V voltage domain)
3	D+	Direction signal +	Positive motor direction signal, differential signal type (5 V voltage domain)
4	D-	Direction signal -	Negative motor direction signal, differential signal type (5 V voltage domain)
5	5V	5V voltage output pin	5V voltage output pin

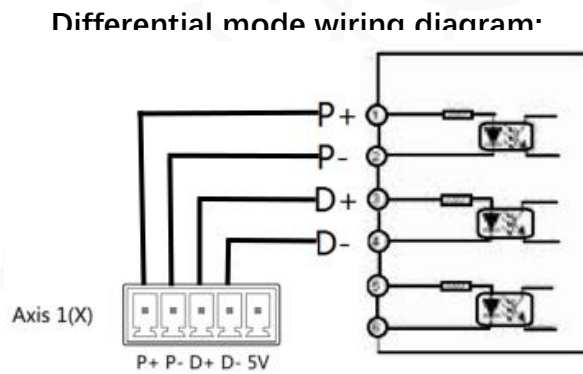
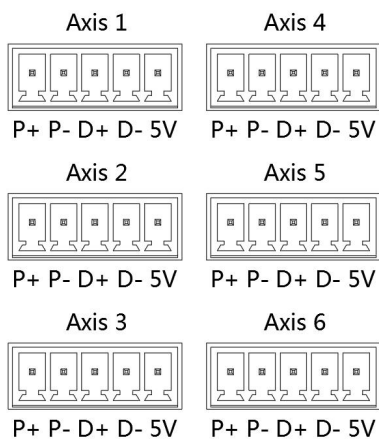

Common anode wiring

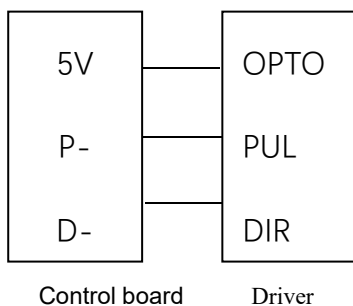

Common cathode

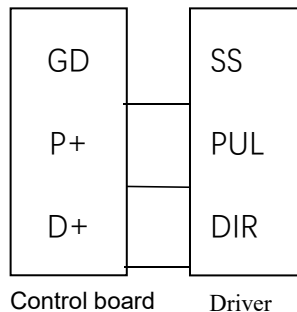

1.6 HMI upgrade instructions

Step 1: If the screen updater is a zip file, extract the zip file to the root directory of the USB flash drive; if it is a folder, copy it directly to the root directory of the USB flash drive (the folder contains the font folder, i.e. various other bin and lua files). Note: The USB stick must be formatted in FAT32 format and the file name must be private, as shown below.



Step 2: Insert the USB flash drive into the USB port of the screen, the screen will automatically detect whether the USB flash drive contains the upgrade file, if so, it will be upgraded directly and automatically, and you can dial out the USB flash drive after the upgrade is completed. If you confirm that the USB flash drive contains the upgrade file, but insert the USB flash drive does not enter the upgrade screen, please reformat the USB flash drive to FAT32 format.

```
DC80480H070_U199_16MB
write 3:/addr_label.lua (100%)...
write 3:/display_record.lua (100%)...
write 3:/image.bin (100%)...
write 3:/lcd.txt (100%)...
write 3:/main.lua (100%)...
write 3:/pingin.bin (100%)...
write 3:/project.bin (100%)...
write 3:/recipe.bin (100%)...
write 3:/font/angsa.ttf (100%)...
write 3:/font/angsab.ttf (100%)...
write 3:/font/angcai.ttf (100%)...
write 3:/font/angfaz.ttf (100%)...
write 3:/font/fangsong_GB2312.ttf (22%)...
```



USB flash drive upgrade pop-up window

Chapter 2 Main interface and key description

2.1 Main interface description

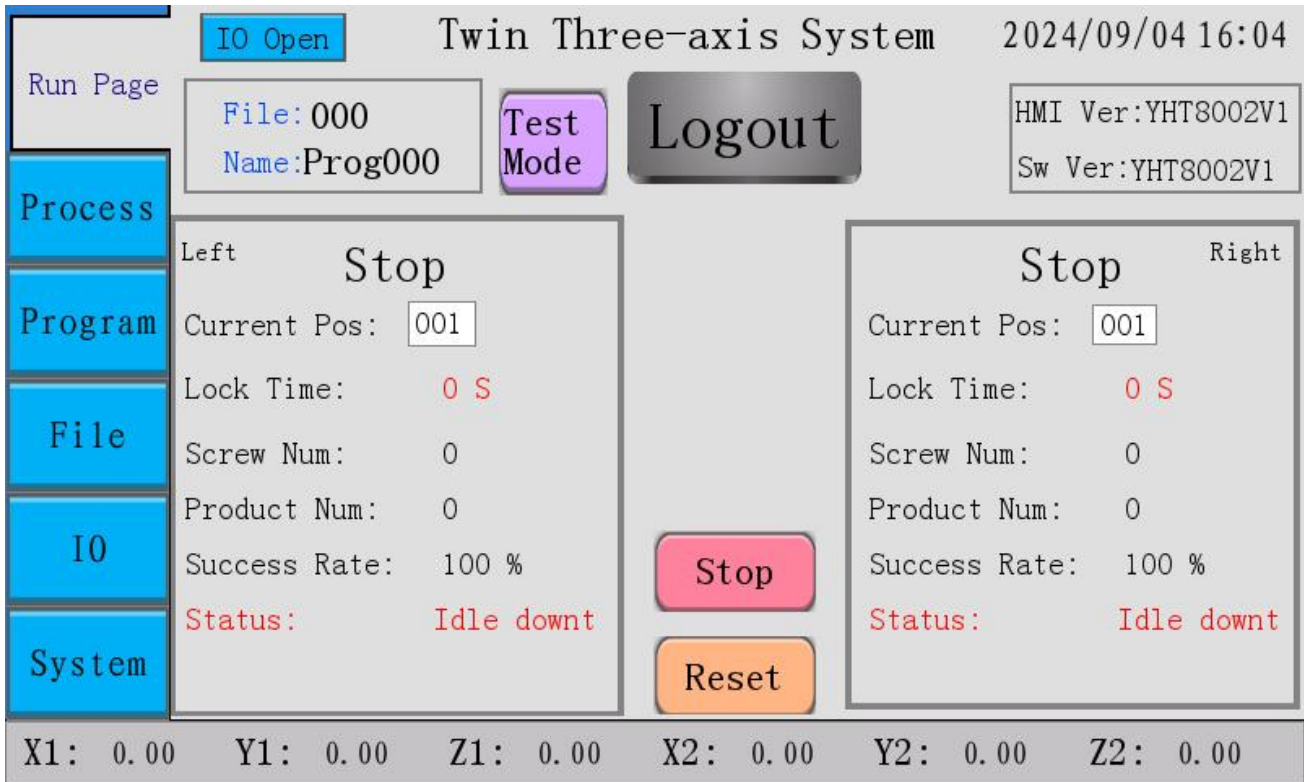

Figure 2-1-1 Processing Run Interface

User: User can not view and set system parameters, the default initial password is 123.

Administrator: Administrator can change and view all parameters, the default initial password is 88888888.

2.2 MiniBOX Teaching Box

1.Connection description

The MiniBOX is connected to the board via serial port COM1 (RS232) and is used for teaching operations during the machining demonstration process.

2.Interface Description



Figure 2-2-1 MiniBOX Diagram

1. **Speed** Manual movement speed "slow, medium, fast" speed switch, short press for "medium, slow" switch, long press 1.5s switch to "fast".
2. **Insert** Inserts a blank programming point in front of the programming point selected by the cursor.
3. **Undo** Undo operations for programming point editing can have a cache of 20 times, effectively preventing misoperation.
4. **GoTo** When the cursor selects the programming point of the screw hole in the teach-in interface and presses the key, it moves to the coordinate value. (Equivalent to moving to the cursor key)
5. **X←** Manual X-axis movement to the left.
6. **Z↑** Manual Z-axis movement upward.
7. **Z↓** Manual Z-axis downward movement.
8. **A↻** Reserved.
9. **X→** Manual X-axis movement to the right.
10. **Y↑** Manual Y-axis forward movement.
11. **Y↓** Manual Y-axis backward movement.

12.  Reserved.

13.  Programming for screw hole entry in the Teach-In interface.

14.  The programming point cursor moves up one line in the demonstration interface.

15.  The programming point cursor moves down one line in the demonstration interface.

16.  Switch left and right machine, short press to switch machine in 6-axis collaborative mode, long press to switch front and rear orientation of the machine. (When the screen and the board can not communicate, then we need to upgrade the board, this time also need to use this button, that is: power off, the USB flash drive into the USB port of the board, and then press and hold this button, and then power on, the system will begin to read the USB flash drive, and then select the file, press the screw hole to confirm the upgrade)

17. `002_TEST01` User-written programming file serial number.

18. `FAST` The XYZ-axis moving speed mode in manual programming is divided into 'fast', 'medium' and 'slow', short press is to switch between 'slow' and 'medium', long press for 2s is to switch to 'fast' mode. 'and 'medium speed', long press 2s to switch to 'fast' mode.

19. `X:000.0 Y: 0.12.4` Real-time coordinate position values during system operation.

`Z:000.2`

20. `GRP: L` is used to indicate the currently selected machine.

In normal mode: L: Left abbreviation for left machine, R: Right abbreviation for right machine.

In six-axis collaboration mode: (F: Front front abbreviation B: Back rear abbreviation).

LF: Front of left machine LB: Behind the left machine

RF: Front of right machine RB: Behind the right machine

21. `001 Hold` The line number of the programming file and the description of the type of the line, 0001 indicates the line number, and the unprogrammed point indicates the type of the content of the line, there are 'unprogrammed point', 'screw hole position', 'non-screw hole' There are three types.

Chapter 3 Group parameters

Group parameters can be set in this interface.

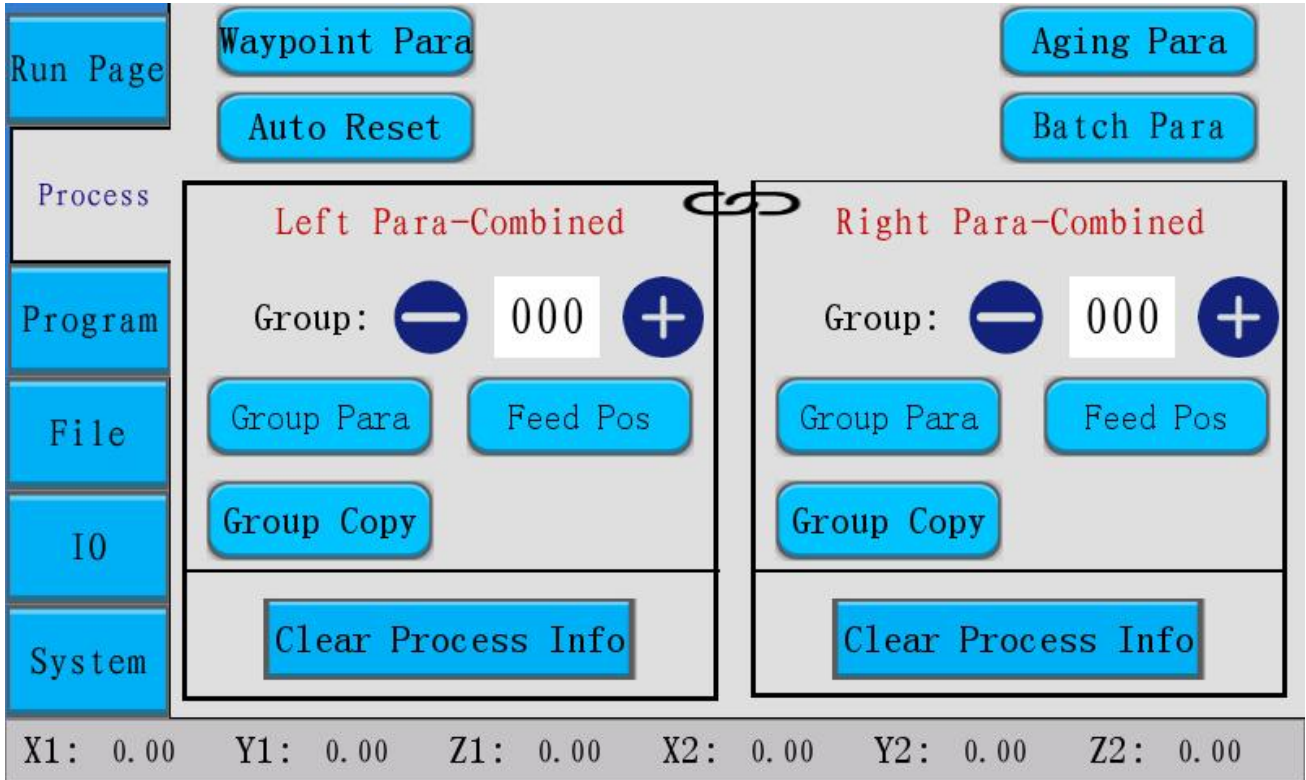

Figure 3-1 group parameter interface

3.1 Way point parameter setting

In this interface, the process parameters of empty points can be set.

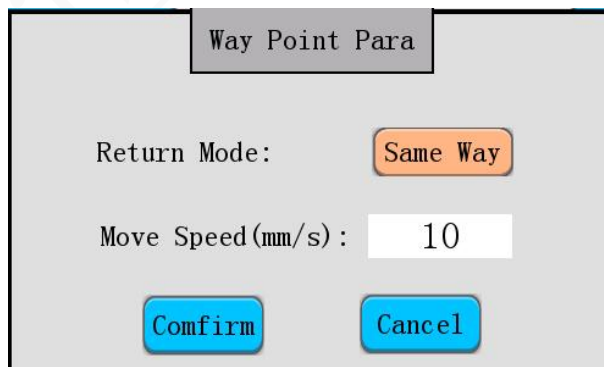

Figure 3-1-1 empty point process parameter setting interface

Return mode: 1. Direct lifting; 2. Return by the same route.

Move speed(mm/s): set the moving speed when walking empty point.

3.2 Automatic reset setting

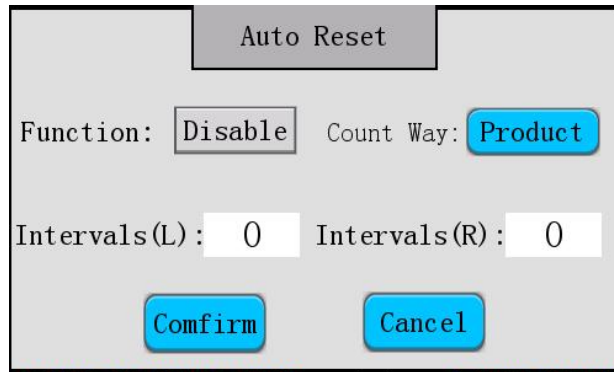

Figure 3-2-1 Auto reset setting interface

Auto reset: one click to toggle on or off.

Counting way: optional workpiece counting or hole counting.

Intervals L (Left machine interval): Set how many times the left machine runs for a reset.

Intervals R (Right machine interval): Set the right machine to run several times to reset once.

3.3 Aging mode parameter setting

In this interface, the aging parameters of the machine can be set, as shown in the following figure.

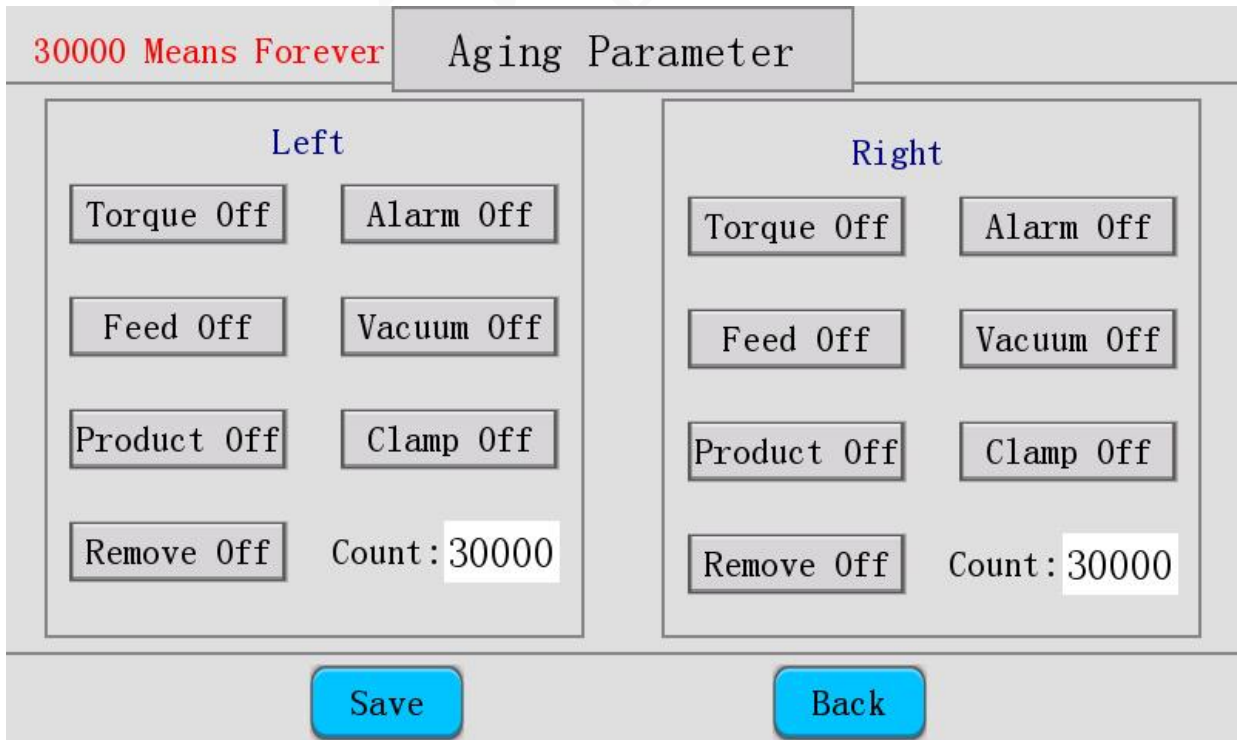

Figure 3-3-1 aging mode parameter setting interface

3.4 Batch parameter setting

This interface allows you to quickly set the parameters of the batch and other related parameters.

Batch Parameter		Tip:Set 0 Disable Function		
Common:		Bat ch1	Finish(In)	0
Type: <input type="button" value="NO"/>	Detect Way: <input type="button" value="Scan"/>		Drive (Out)	0
Rotation Mode: <input type="button" value="All Time"/>		Bat ch2	Free (Out)	0
Blow: <input type="button" value="Disable"/>			Cylinder Origin	0
Duration: <input type="text" value="0.00 S"/>	Intervals: <input type="text" value="0"/>	Bat ch3	Batch Cylinder	0
			Action Delay(s)	0
Torque Clr: <input type="button" value="Disable"/>	Detect Time: <input type="text" value="0.00 S"/>	Bat ch4	Deep Detect	0
Retry Times: <input type="text" value="0"/>	Drive Time: <input type="text" value="0.00 S"/>		Blow Clean	0
<input type="button" value="Smart Batch"/>		<input type="button" value="Save"/>		<input type="button" value="Back"/>
				<input type="button" value="Life Span"/>

Figure 3-4-1 Electric batch parameter setting interface

Torque signal type: normally open and normally closed can be selected.

Testing mode: scanning or capturing mode can be selected.

Electric batch rotation mode: there are four modes to choose, 1. full rotation 2. stop when moving 3. only processing rotation 4. magnetic suction.

Full rotation: the batch is rotating all the time during machining.

Stop while moving: During machining, the batch is turned off when the axis moves and turned on when the axis stops.

Processing rotation only: The batch rotates only when locking the attached screws.

Magnetic suction: then the batch is on after taking the screws and until locking the screws.

Blow to clean: can be selected to open or close, when it is open, it will output the clean blow port on the right side of Fig. 3-5 after locking and paying is completed, and the delay time will be closed.

Duration: blowing delay time in seconds.

Interval times: the number of blowing times.

Torque Clear: To open this function, you need to open the torque detection in the group parameter first. The function is to clear the completion signal in the right side of Fig. 3-5 before locking the screws to avoid abnormal lock attachment.

Torque Detection Delay Time: After the output of the forward drive port is turned off, the completion signal will be detected within the time period.

Retry times: If the completion signal can be successfully cleared within this time, then the locking action can be carried out, otherwise the torque clearing failure will be reported.

Drive Output Time: Positive turn drive port output delay time.

Completion Input Port: The signal will be given after the locking is OK in the electric batch.

Positive rotation output port: locking screws, after locking OK, even if the port has been outputting the batch will stop rotating.

Free turn output port: It does not detect whether the locking is OK or not, as long as there is this signal, the batch will keep rotating.

Electric batch cylinder home position: Electric batch downward pressure cylinder home position input port.

Electric batch cylinder output port: output port of electric batch lowering cylinder.

Cylinder in place delay time(s): the delay time of the electric batch lowering cylinder pressing down.

Depth detection input signal: Signal for detecting whether the screw is in place.

[Intelligent electric batches]

To use this function, you need to set the batch brand and baud rate in the machine structure settings now.

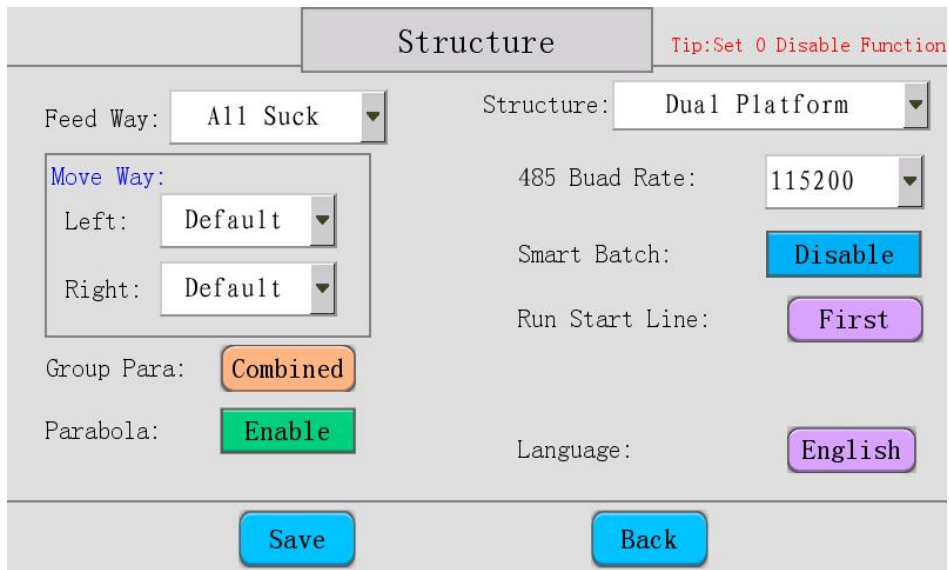

Figure 3-4-2 Machine Structure Setting Interface

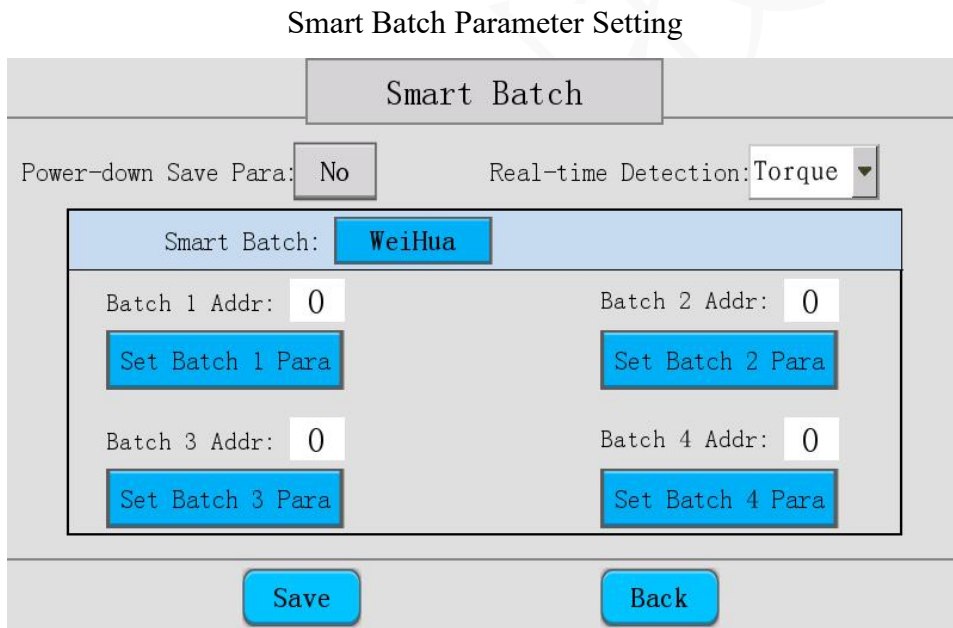

Figure 3-4-3 Smart Batch Parameter Interface

Power down saving of batch parameters: No/Yes option.

Real-time monitoring of batch parameters: torque/speed/number of revolutions can be selected, and real-time machining parameters can be displayed according to this option in the machining interface.

Batch address: the slave number of the batch, must match with the actual batch address, note that the address of each batch can not be set the same.

Batch Parameters: The parameters of different batches are different, please set the parameters according to the actual brand.

3.5 New group parameter file

Edit group parameter: press -/+ sign to switch processing parameter group, single side machine supports 256 processing parameter groups, left and right machine supports 512 groups of group parameters in total.

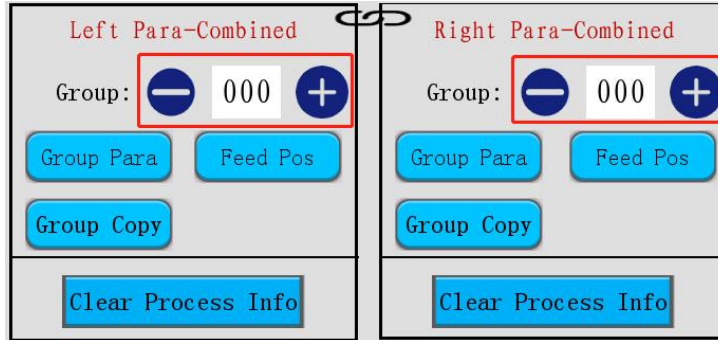

Figure 3-5-1 New Group Parameters Screen

3.6 Edit group parameters

Click the [Edit Group Parameters] button to open the parameter editing interface, which is shown in Fig. 3-6-1-1, Fig. 3-6-2-1, Fig. 3-6-3-1 and Fig. 3-6-4-1.

3.6.1 Processing parameter interface



Figure 3-6-1-1 Processing Parameter Interface

Electric batch selection: 1# 2# 3# 4# 1#&2# 3#&4# Two electric batches working at the same time is only useful in blowing mode.

Material on/off: click to switch the report on or off, set to 'on', every time you pick up the material will detect the material supply signal, will go down to pick up the material, after picking up the material, the material supply signal will disappear, picking up the material action is complete, such as the material supply signal is not disappeared, it is considered that the screws are not picked up, it will be picked up again until the screws are picked up. 2. Set to 'Off', go to fetch the material directly without detecting the feeding signal.

Torque On/Off: Click to switch the report on or off, at this time the electric batch torque signal is open, the electric batch according to the length of the follow up to play screws. If the follow-up length is completed and has not detected the torque signal, 'screwing delay' to start timing, then in the screwing delay time to detect the torque signal, no torque is detected, then the alarm 'slippery teeth'.

Alarm on/off: Click to switch the alarm on or off, set to 'open', generate 'slippery teeth', 'floating lock' alarm. Set to 'Off' to ignore the alarm.

Vacuum On/Off: Click to switch the vacuum on or off.

Vacuum On/Off: Click to toggle the setting to Vacuum On or Vacuum Off. (Empty lock is in the suction mode, no pickup action, only screw action)

Disassembly on/off: Click to switch the setting to disassembly on or disassembly off. (This dismantling material, means that this hole is only for removing screw action)

Batch: Specify the batch to be used when machining with the programming points of this group of processes, and support the selection of one or more batches. (Example: Setting to #1 means using the No.1 electric batch for machining.

Follow-up speed: It is the speed of Z-axis to follow the screw down when the batch opens and starts to hit the screw when it reaches the screw hole.

Follow-up length: It means the length of Z-axis following the screw down after the electric batch opens and starts to drive the screw when it reaches the screw hole, and it is usually set to be a little longer than the length of the screw.

Running Speed Setting: Set the moving speed of each axis when working, reference value: 50-1000.

Speed X (mm/s) :	600
Speed Y (mm/s) :	600
Speed Z (mm/s) :	600

Figure 3-6-1-2 Empty shift speed setting interface

Maximum locking time:

- 1) Torque open: If no blocking signal is detected within this time when the batch is locked in place, the alarm will be ‘Slip’;
- 2) Torque off: the batch rotates for the set time when it is locked.

Dwell time after completion: delay time after completion of work. The function is to wait for the Z-axis cylinder to return to the place after locking, if there is no Z-axis cylinder, it can be set to ‘0’.

Float Lock Judgement Time: If a blocking signal is detected within the set time, the alarm will be ‘Float Lock’. (Float lock judgement time < Successful locking time < Maximum locking time)

Feed completion delay time: in suction mode, the machine stays in the pickup position for a period of time. Used to increase the success rate of material picking.

Hole Height: When going to the screw hole position, it reaches above the screw, the height of Z-axis, when leaving the screw hole position, it leaves above the hole, the height of Z-axis. Prevents the batch head from colliding with the product on the workpiece.

Taking height: the safety height when going to the feeder to take screws, generally set to be slightly larger than the height of the nut.

Screw length: the safe height to leave after going to the feeder to take screws, generally set to slightly longer than the screw length.

3.6.2 Supply Parameters Screen

Process	Support	Transit	Remove	Left 000Group	
Ask/Suck Screw Signal 1:	0	Ask/Suck Screw Signal 2:	0	Close Suck(s):	0
Screw Ready Signal1:	0	Screw Ready Signal2:	0	Type:	NC
Suck Take Way:	Suction	Support		Ask Duration(s):	0
No Screw Retry:	Close	Failed Retry Times:	0	Detect Time(s):	0
Detect:	Close	Vacuum Detect Port 1:	0	Vacuum	Feeder Pos
Type:	NC	Vacuum Detect Port 2:	0		Feed Test
Save			Back		

Figure 3-6-2-1 Feed Parameter Screen

Request/suction screw 1 (output):

Suction mode: Suction signal;

Blow mode: blow out screw signal/request signal.

Suction signal off delay: The suction signal is turned off after a set time delay when machining is started in suction mode.

Screw ready signal 1 (input):

Suction mode: Screw ready signal;

Blow mode: screw blow-out signal.

Screw ready signal type:

Suction mode: feeder ready signal type.

Blow mode: Screw blow out signal type.

Suction pickup mode: selectable vacuum adsorption or jaws/magnetic suction.

Duration of material to be fed: the duration of material to be fed signal in blowing mode.

Repeat without re-feeding: enable to choose to repeat without re-feeding when screw playing fails.

Retry times after picking failure: the number of times to retry when picking screws fails, over this number of times will report 'picking screws failed' alarm.

Detect time to material: the longest time to detect the arrival of screws in blowing mode.

Vacuum detection: check whether the vacuum adsorption is successful when fetching materials.

Vacuum detection type: normally closed and normally open can be selected.

Vacuum detection letter 1: Vacuum detection input port.

Supply feeder 1 position:

Suction mode: sets the position (coordinates) of the feeder under the current group process.

Blow Mode: Invalid parameter.

Supply 1 Pickup Test:

Inhale Mode: Performs a pickup test of the feeder under the current grouping process.

Blow mode: execute the current group process under the material to be tested, material to be failed to alarm: 'Fetch Failure'.

Suction vacuum test: in suction mode, in this interface, you can set the function status (open/closed), signal type (normally open/closed) and batch vacuum signal port for vacuum test.

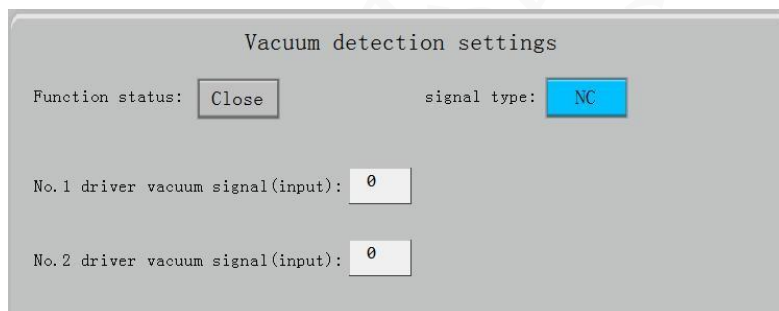

Figure 3-6-2-2 Vacuum Detection Setting Screen

3.6.3 Transit Parameters screen



Figure 3-6-3-1 Transit Parameter Interface

Transit function: Mainly used for embedding part of the components or gluing in the middle of the process.

Staging position: The corresponding staging position can be set.

Entering safe height: The height of Z-axis lifting when moving to the staging position.

Leaving safe height: The height at which the Z-axis is lifted when leaving the staging position for screw-hole attachment.

Lift Stabilisation Time: The delay time for stabilisation of the Z-axis after lifting.

Dipping length: the length of locking attachment.

Dipping speed: Z-axis lowering speed.

Dwell time: Dwell time after the seeping action is completed.

Viscosity Push Staple Cylinder: Input after Z-axis is in place, and close after delay time.

3.6.4 Screw removal parameter interface

Process	Support	Transit	Remove	Left 000Group
Remove:	<input type="text" value="Disable"/>		Throw:	<input type="text" value="Disable"/> <input type="button" value="Throw Pos"/>
Batch Reversal Port:	<input type="text" value="0"/>		Blow Signal Port:	<input type="text" value="0"/>
Finish Delay(s):	<input type="text" value="0"/>		Blow Duration(s):	<input type="text" value="0"/>
Delay Before Start(s):	<input type="text" value="0"/>		Remove Sp(mm/s):	<input type="text" value="30"/>
Delay After Start(s):	<input type="text" value="0"/>		Remove Len(mm):	<input type="text" value="12"/>
			Buffer Height(mm):	<input type="text" value="0"/>
<input type="button" value="Save"/>			<input type="button" value="Back"/>	

Figure 3-6-4-1 Screw Removal Parameter Interface

Function Status: Enable or disable the screw removal function. Setting ‘On’ means the screw removal function is enabled, and the default is ‘Off’.

Electric batch reversal signal (output): drive the output port of electric batch reversal signal.

Delay after upward completion (s): delay after the screws are removed and ready to go to the throwing position, used to wait for the equipment to return to the place such as pressing down.

Delay before start-up of electric batch (s): dwell time before start-up of electric batch reversal to ensure accurate alignment.

Delay after start-up of electric batch (s): dwell time after start-up of electric batch reversal to ensure adequate contact between screws and batch head.

Throwing screws: Turn on or off the function of throwing screws. If the setting is ‘On’, it means the screw throwing function is enabled, and the default is ‘Off’.

Throwing position: Set the position for placing the screws after removing them. This parameter is effective only after the screw throwing function is turned on.

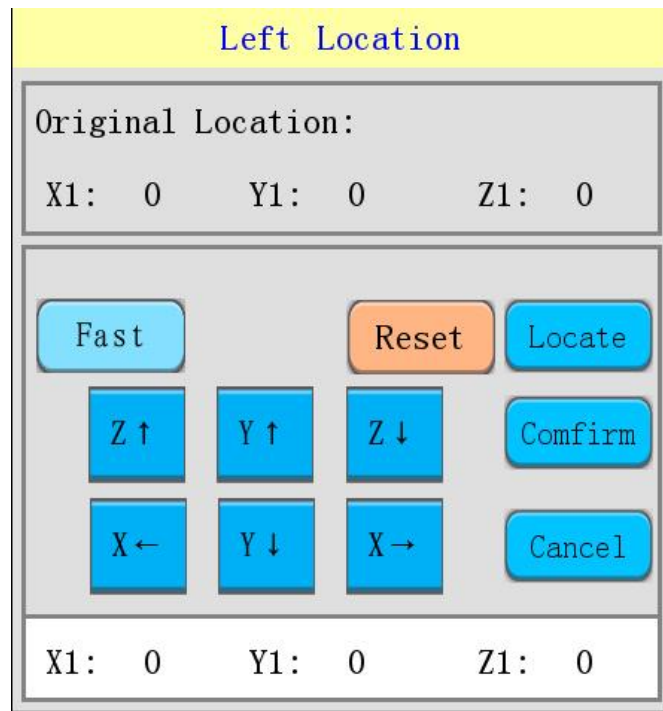

Figure 3-6-4-2 Throw/Intermediate/Feed Position Setting Screen

Blowing level blowing signal (output): blow away screw control signal for blowing out the removed screws.

Blowing Duration (s): The duration of the blow away screw signal to ensure that the screws can be blown away.

Screw removal speed (mm/s): Z-axis lifting speed for removing screws.

Screw removal length (mm): Z-axis lifting length when removing screws.

Cushion height before position (mm): for cushioning the alignment when removing screws and slow contacting the screws.

3.7 Group Supply Position

Set the left/right machine group feeder position.

3.8 Group parameter copying

Group parameter replication on the same machine supports copying a file to multiple files.

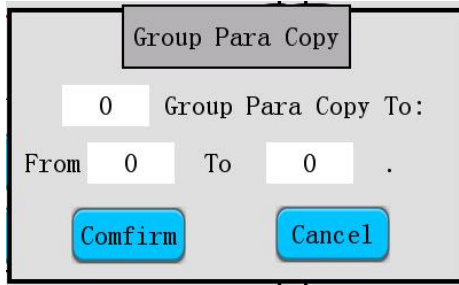

Figure 3-8-1 Group Parameter Copy Screen

3.9 Cross-machine replication of group parameters

Support left and right machine group files to copy each other.

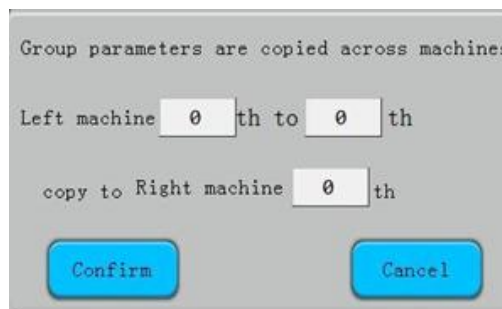

Figure 3-9-1 Cross-Machine Copy Interface

3.10 Clear processing information

Click on 'Clear Processing Information' to clear the parameter information in the 'Processing Operation' interface, i.e. the information parameters indicated in the box below.

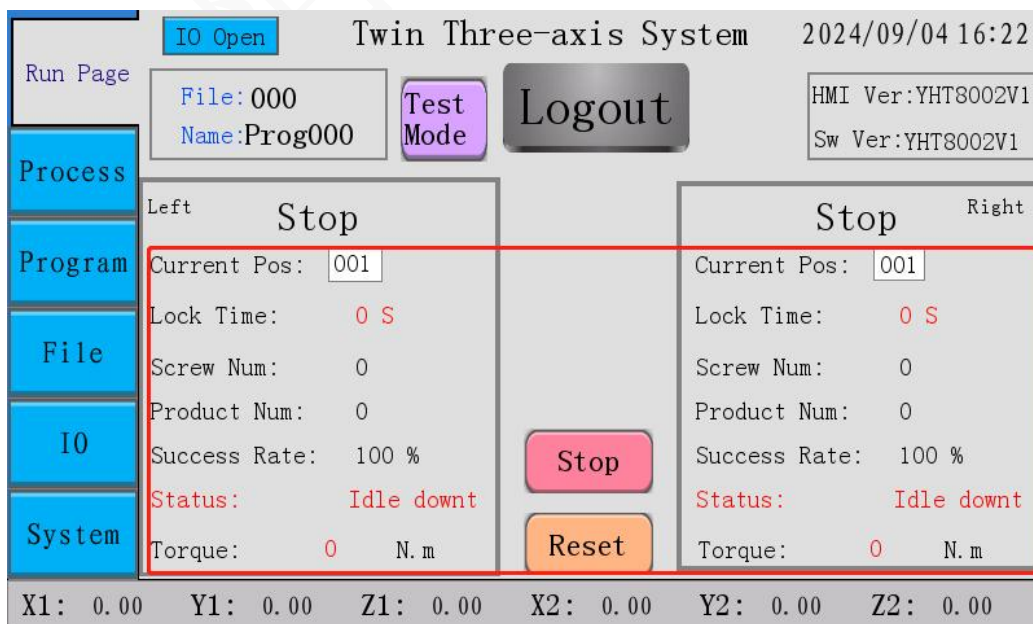

Figure 3-10-1 Machining Operation Parameter Interface

Chapter 4 Teaching Programming

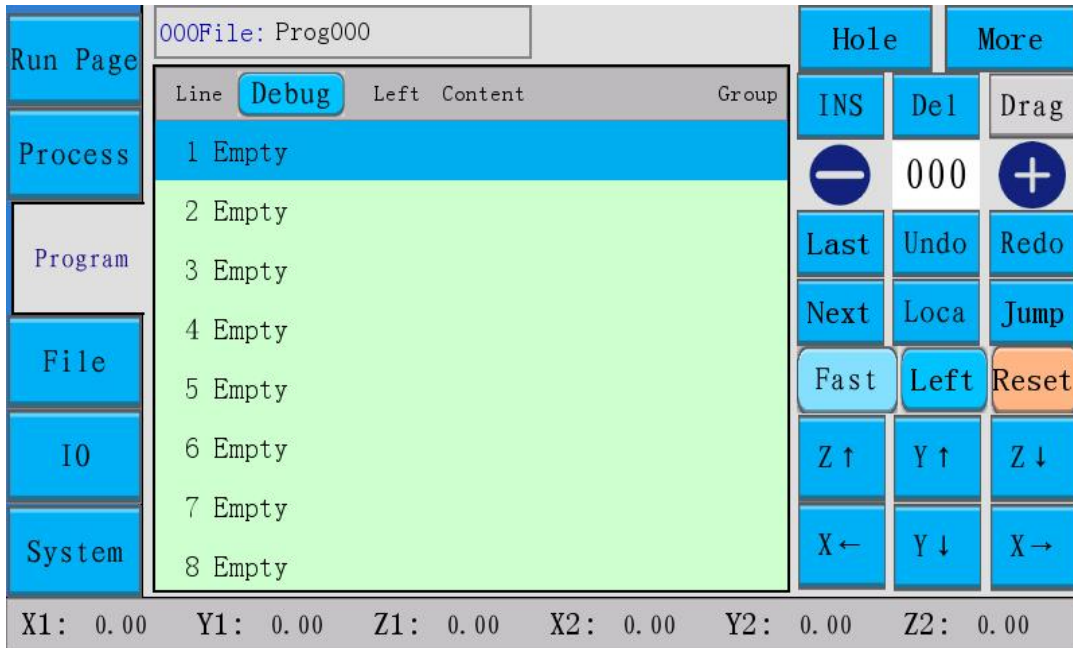
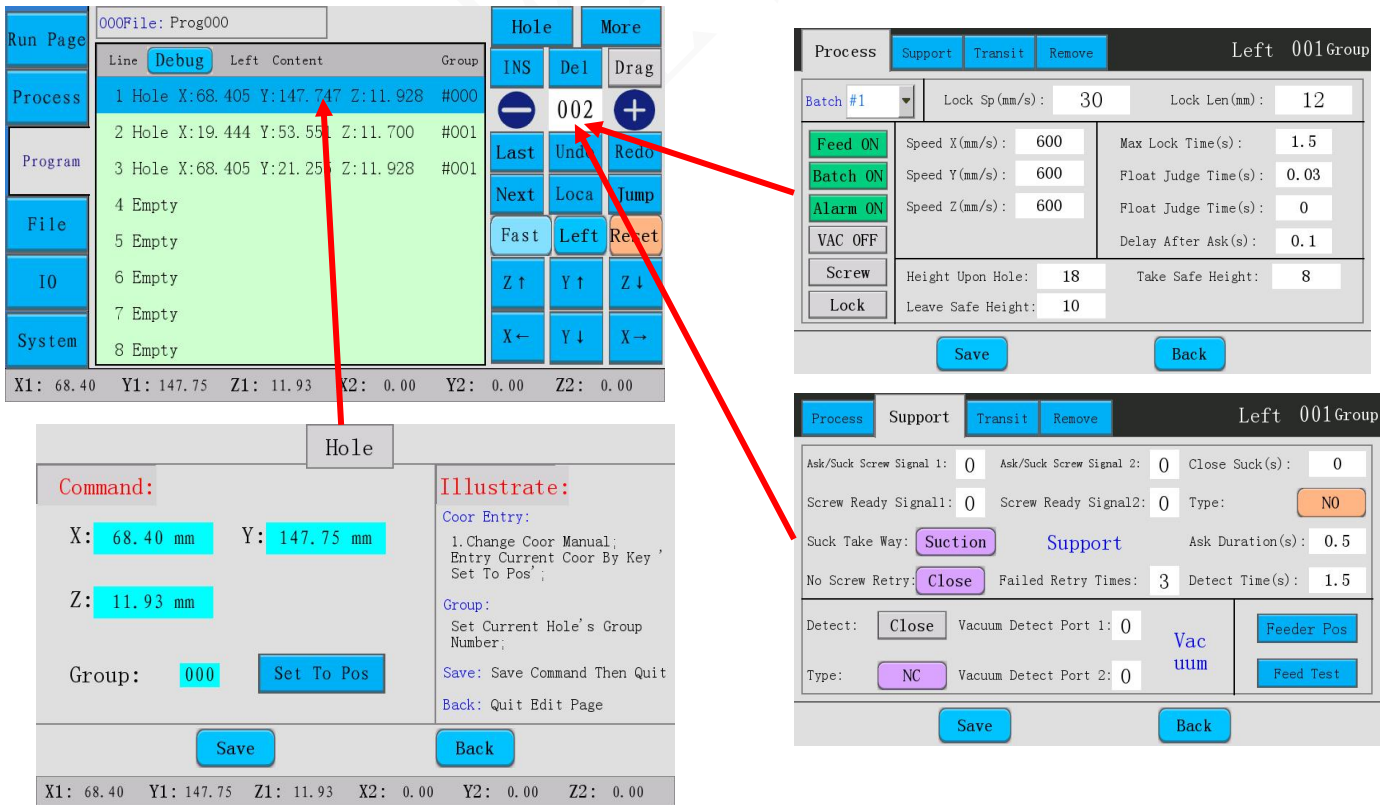

Figure 4-1 Teaching Programming Interface

4.1 Teach-In-Interface



4-1-1 Teaching Programming Detail Screen

Line number: A file can store up to 900 machining programming points.

[Error Removal]: Execute the analysis of the current machining program file programming points whether to meet the programming requirements, click the [Error Removal] button, such as meet the programming requirements of the icon will turn grey font. If it does not meet the editing requirements, the system will remind the cause of the error.

4.2 Axis Motion Button



Manually control the X-axis of the currently active machine to move to the right.



Manually control the X axis of the currently active machine to move left.



Controls the forward movement of the Y-axis of the currently active machine.



Manually control the Y-axis backward movement of the currently activated machine.



Manually control the Z-axis upward movement of the currently active machine.



Manually control the downward movement of the Z-axis of the currently active machine.

4.3 Function button



Performs a home return action.



Switching left and right machines.

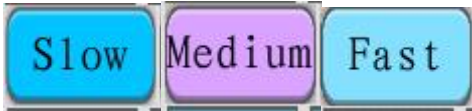

Manual movement speed 'slow', 'medium' and 'fast' switching.



Undo and redo for programming point editing can have 20 operations, effectively preventing misoperation.



Undo and redo for programming point editing can have 20 operations, effectively preventing misoperation.



The cursor selects the screw hole programming point and presses the change button to move to that coordinate value.



Quick access to the Programming Point Cursor Jump dialogue box.



Move cursor up one page.



Move the cursor down one page.



Performs screw hole entry programming.



Inserts blank programming lines.

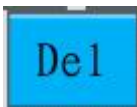

Deletes the programming point selected by the cursor.



Brown indicates that the drag-and-drop function is on, and grey indicates that the drag-and-drop function is off. Please refer to 'Chapter 7 7.12' for the setting and use of the drag and drop function. 7.12.1 Driver Parameters' for "Drag & Drop Function Settings".

4.4 More Functions Button

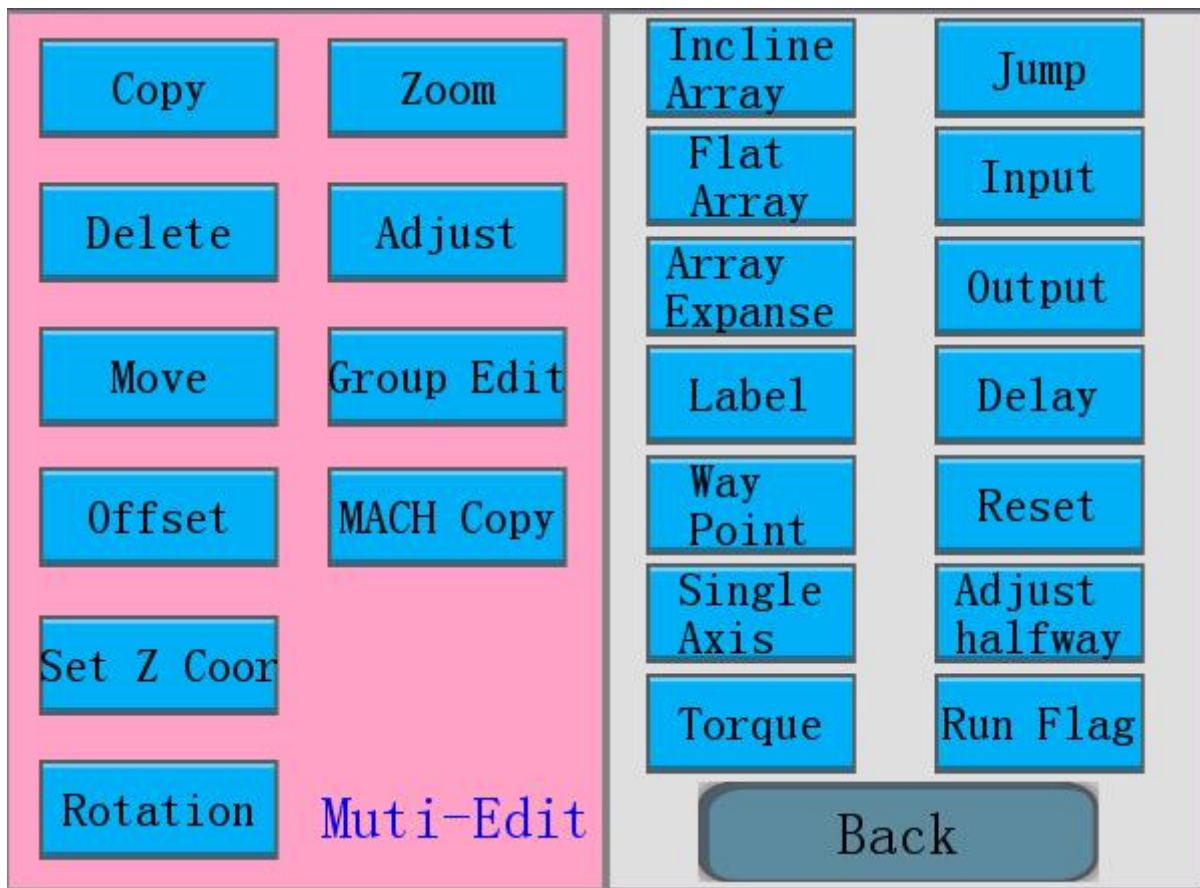

Figure 4-4-1 More Functions Programming Interface

1. Copying

Copies the programming point within the edit range to the specified programming point address.

2. Delete

Deletes programming points within the edit range.

3. Move

Moves the programming point within the editing range to the specified programming point address. This function is mainly used to adjust the machining sequence of each screw.

4. Coordinate offset

Offset the coordinate values of the programming points of the screw holes within the editing range.

5. Set the Z-axis coordinates

Set the same Z-axis coordinate value for the programming point of the screw hole position within the editing range.

6. Planar rotation

Rotate the programming points of the screw holes within the editing range, mainly because if the fixture is deformed and rotated you can use this function to correct it without having to reprogramme it.

7. Zoom

Enlargement or reduction of the programming point graphics of the screw holes within the editing range is mainly used to correct the deviation of the processing size from the actual size caused by the accuracy of the machine after using the DXF file to generate the processing file.

8. Teaching offset

Generally used in CAD guides to teach offsetting a point on the CAD from the corresponding point on the workbench. The programming point of the screw hole in the editing range is offset by the coordinate value accordingly.

9. Modify group

Batch modification of multi-line grouping parameters.

10. Machine copying

Copies all programming points from the current machine to another machine.

4.4.1 Inclined Array

Incline Array	
Command:	Illustrate:
Incline: <input type="text" value="Horizon"/> Recall Mode: <input type="text" value="Addr"/>	Incline Array: Offset-H's Pos Is Horizont 's Last Hole, Offset-V's Po s Is Vertical's Last Hole.
Number(H) : <input type="text" value="0"/> Number(V) : <input type="text" value="0"/>	Recall Mode: Array Program Start By Address/Label
Offset-H(mm) : X: <input type="text" value="0.00"/> Y: <input type="text" value="0.00"/> Z: <input type="text" value="0.00"/>	Save: Save Command Then Quit
Offset-V(mm) : X: <input type="text" value="0.00"/> Y: <input type="text" value="0.00"/> Z: <input type="text" value="0.00"/>	Back: Quit Edit Page
Address: <input type="text" value="1"/>	
<input type="button" value="Save"/>	<input type="button" value="Back"/>
X1: 68.40 Y1: 147.75 Z1: 11.93 X2: 0.00 Y2: 0.00 Z2: 0.00	

Figure 4-4-1-1 Tilted Array Interface

Such as processing fixture plate placed on a number of vertical and horizontal arrangement of workpieces, and vertical and horizontal respectively, the same spacing can be used when the array, as long as the processing of a workpiece is programmed, and then use the array can be achieved by the processing of the whole plate of workpieces, so that the programming efficiency is greatly improved. This array requires that the fixture plane where the workpieces are placed is not the same as the XY plane, or the horizontal and vertical directions are not parallel to the X and Y axes.

4.4.2 Flat arrays

Flat Array	
Command:	Illustrate:
Flat Way: <input type="text" value="Horizon"/> Recall Mode: <input type="text" value="Addr"/>	Flat Way: Copy Hole By Para You Set With Horizontal/Vertical
Number (H): <input type="text" value="0"/> Offset-H(mm): <input type="text" value="0.00"/>	Recall Mode: Array Program Start By Address/Label
Number (V): <input type="text" value="0"/> Offset-V(mm): <input type="text" value="0.00"/>	Save: Save Command Then Quit
Address: <input type="text" value="1"/>	Back: Quit Edit Page
<input type="button" value="Save"/>	<input type="button" value="Back"/>
X1: 68.40 Y1: 147.75 Z1: 11.93 X2: 0.00 Y2: 0.00 Z2: 0.00	

Figure 4-4-2-1 Flat Fixture Array Interface

Such as processing fixture plate placed on more than one horizontal and vertical arrangement of the workpiece, and the horizontal and vertical respectively, the distance between the same can be used array, as long as the programming of a workpiece processing, and then the use of the array can be achieved by the processing of the whole plate of workpieces, so that the programming efficiency has been greatly improved. This array requires that the fixture plane of the workpiece is the same as the XY plane, and that the horizontal and vertical directions are parallel to the X and Y axes.

4.4.3 Labeling

Label : Markers can be used for calls to arrays, loops, calling subroutines, program jumps, and general-purpose input programming, etc. They can also be used to annotate programming to improve its readability.

4.4.4 Array Expansion

Array Expand : The main interface of the cursor selected array programming points, the implementation of the array to expand the operation can be generated with the same effect as the array of programming points, in the jig disc is not very regular use of this function can then be individual modification of the location of the screw holes of each workpiece.

4.4.5 Output Programming

Output : When the programme is executed to the output signal programming point, the output signal specified in the programming point will output the corresponding set value, 1 for the corresponding output port and 0V conduction, 1 for the corresponding output port external float. When debugging the machine, you can test the corresponding output port, such as electric batch start, control the solenoid valve suction, clamping cylinders and so on.

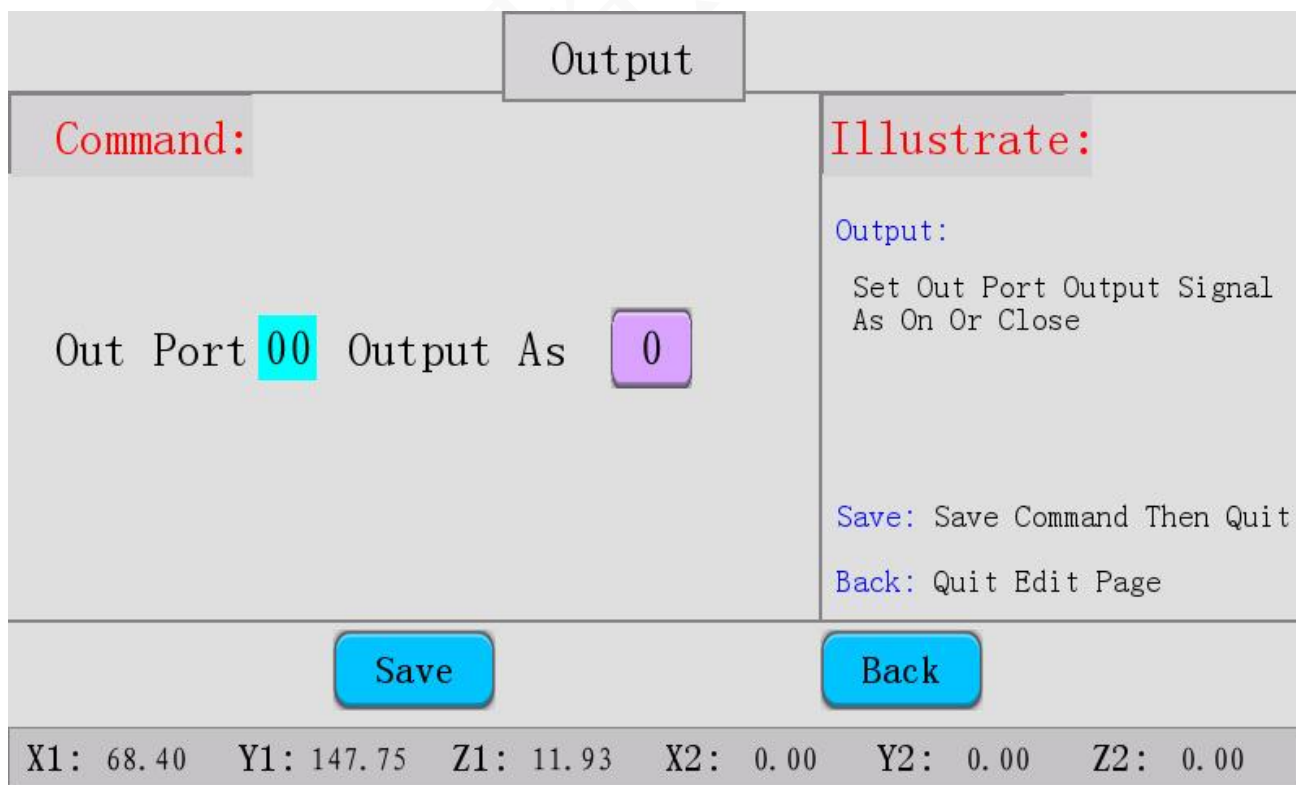

Figure 4-4-5-1 Output Programming Screen

4.4.6 Input Programming

Input : The function of input signal programming is that when the programme is executed to the programming point, if the input state of the specified input signal meets the programmed value, the programme jumps to the specified address or mark, if not, the programme continues to execute. This function can be used to achieve some work with other equipment or as a pause key input. (Signal definition: 1 is when the input is pulled down to 0V externally, 0 is when the input is not pulled down to 0V externally.)

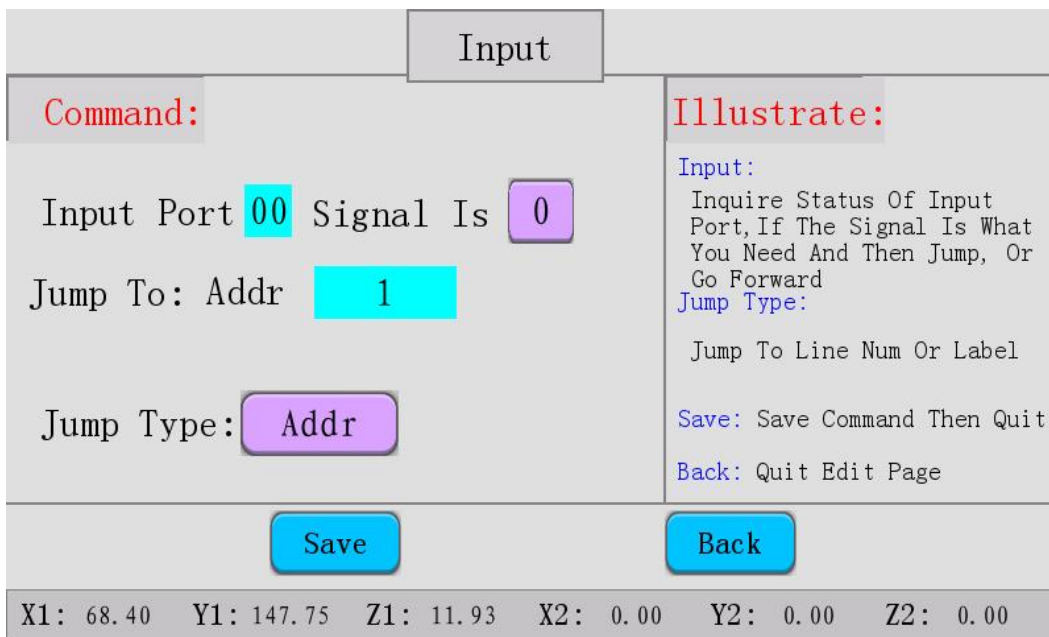

Figure 4-4-6-1 Input Programming Screen

4.4.7 program jump

Jump : When execution reaches this programming point then the programme jumps to the specified address or mark for execution, generally used for loops, etc.

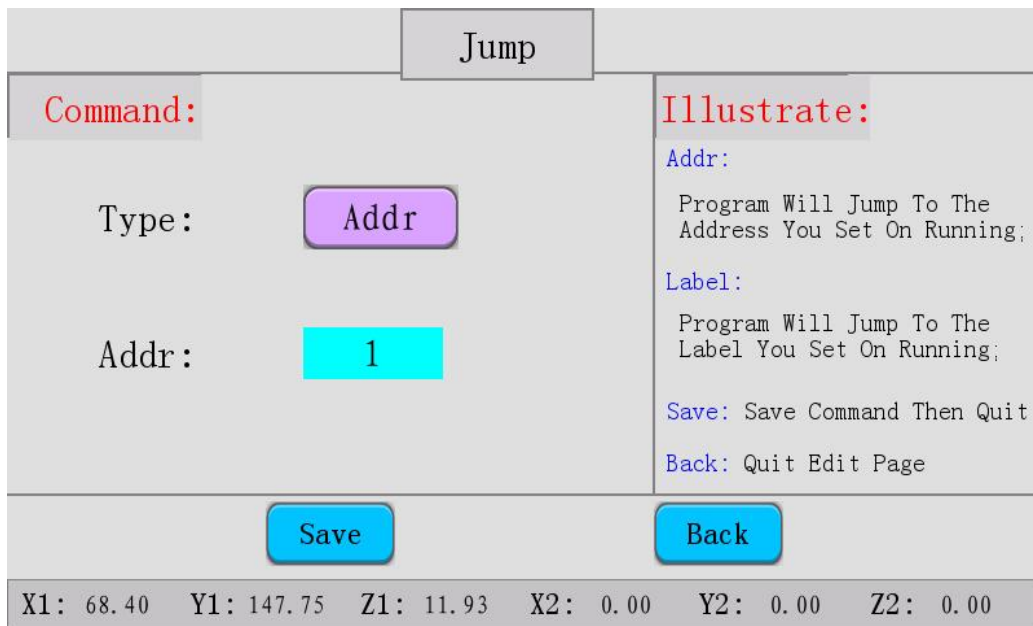

Figure 4-4-7-1 Procedure Jump Interface

4.4.8 Delay

Delay: If the programme is executed to a delayed programming point, the machining is stopped and delayed for a certain period of time before proceeding to the next machining programming point.

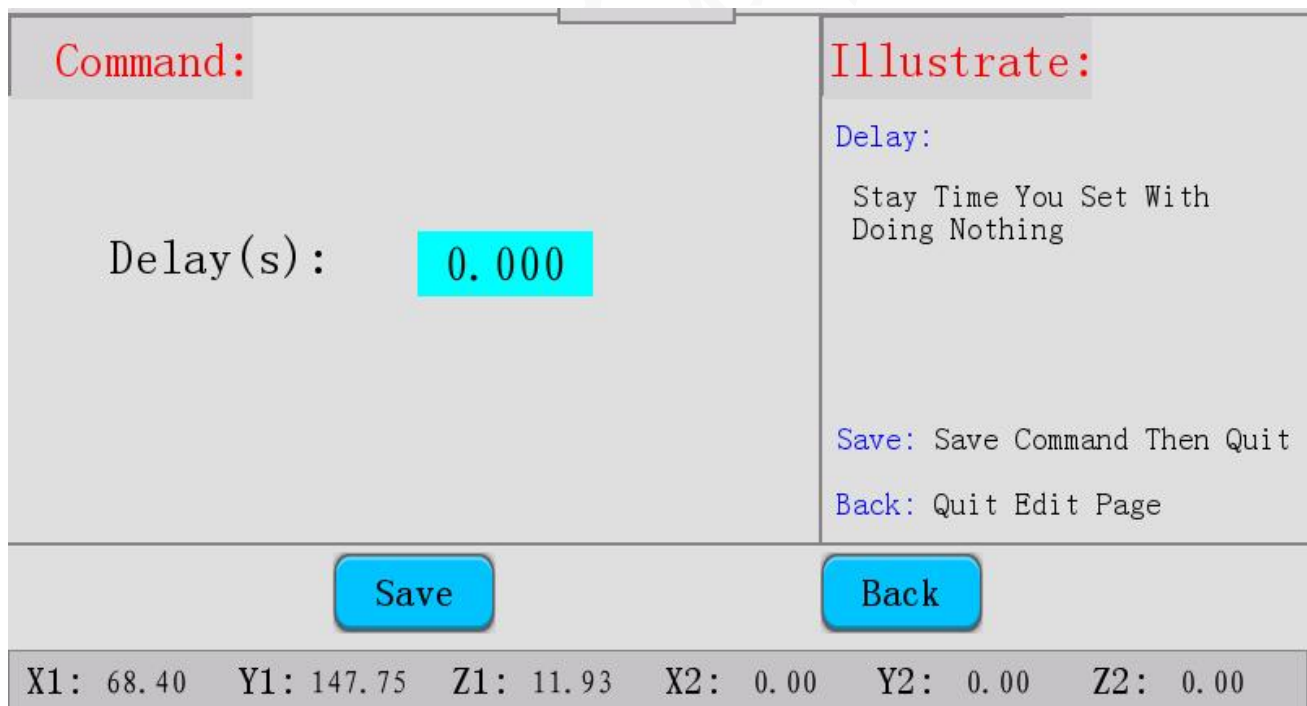

Figure 4-4-8-1 Delay Screen

4.4.9 Back to the original point.

Reset: After inserting this programming point, the machine performs a home return when the programme runs to this programming point.

4.4.10 Single axis motion

Single Axis: Setting up a single axis movement. Click on **X** to switch axes, move the machine manually to the corresponding position and click on the 'Save' button to insert the programme.

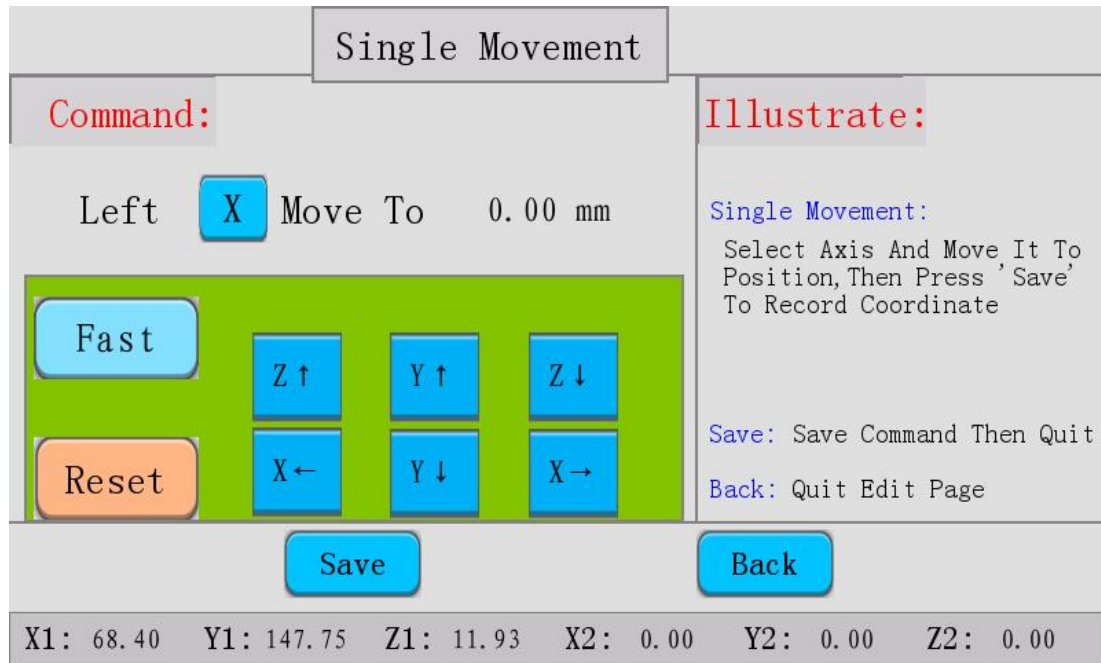

Figure 4-4-10-1 Single-axis motion programming interface

4.4.11 Empty point

Empty point is like the screw hole position point to go to the coordinates of the point, but does not do other actions, for locking screws to walk the obstacle avoidance path to use.

4.4.12 Midway adjustments

Allow the machine to perform midway adjustment of the product action, for the product in the process of adding a cover plate and adjusting the product and other processes to use.

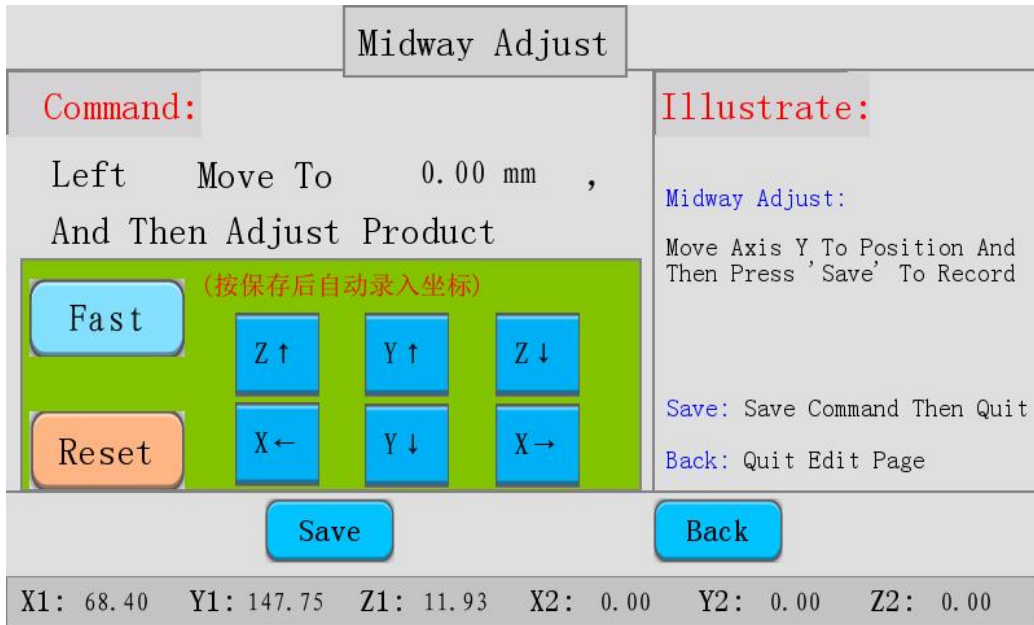

Figure 4-4-12-1 Midway Adjustment Programming Screen

Chapter 5 Files

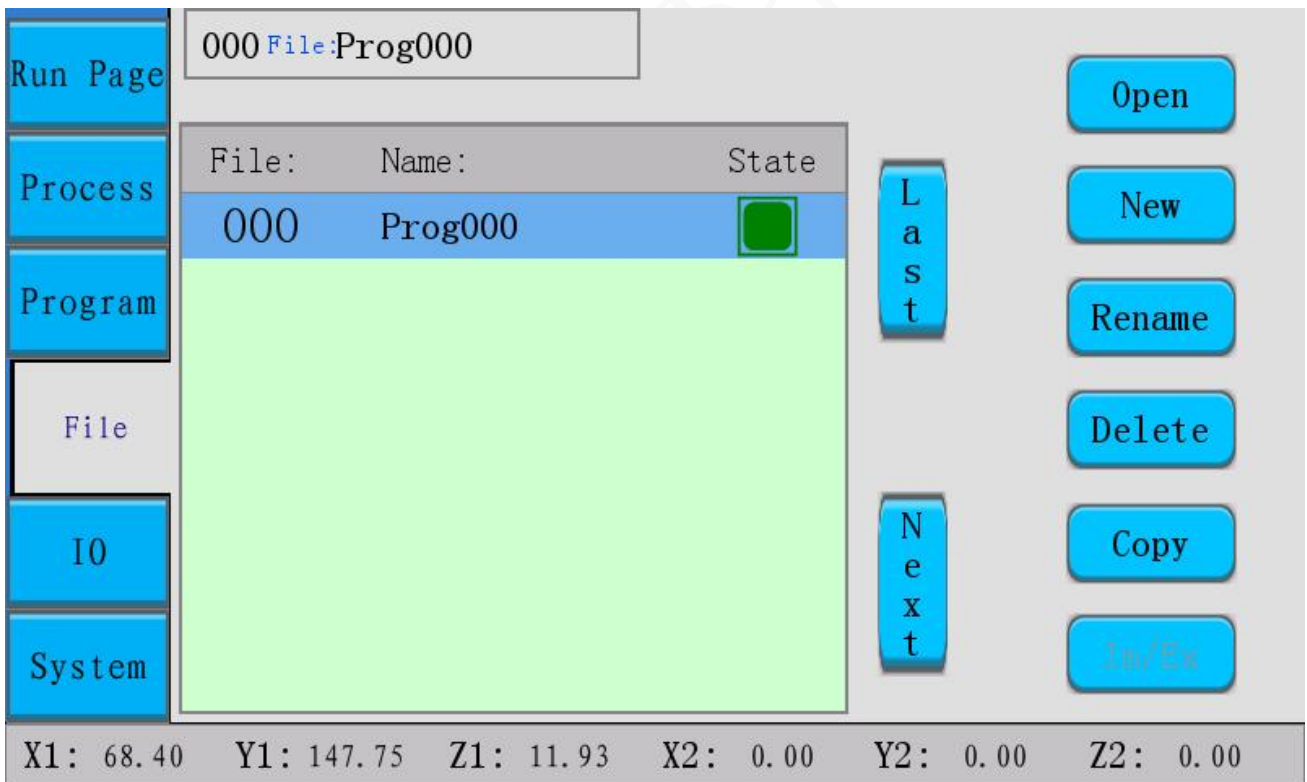

Figure 5-1 File Operation Interface

New File: Click the New button to pop up the following pop-up box, firstly, enter the file number, the value range 0-99, and secondly, enter the file name (does not support Chinese editing), finish editing and press the OK button to save.

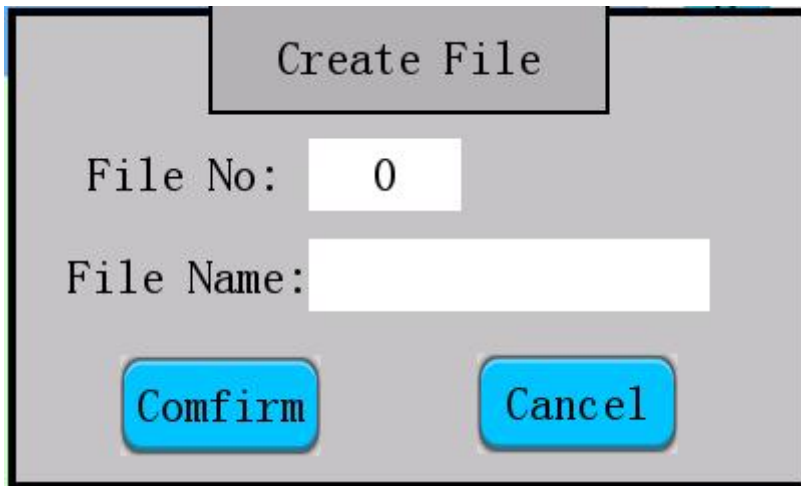

Figure 5-2 New File Interface

Open File: Move the cursor and click the file status to select to open the file.

Rename: Click the 'Rename' button to bring up the renamed file, enter the new file name and click the OK button to save.

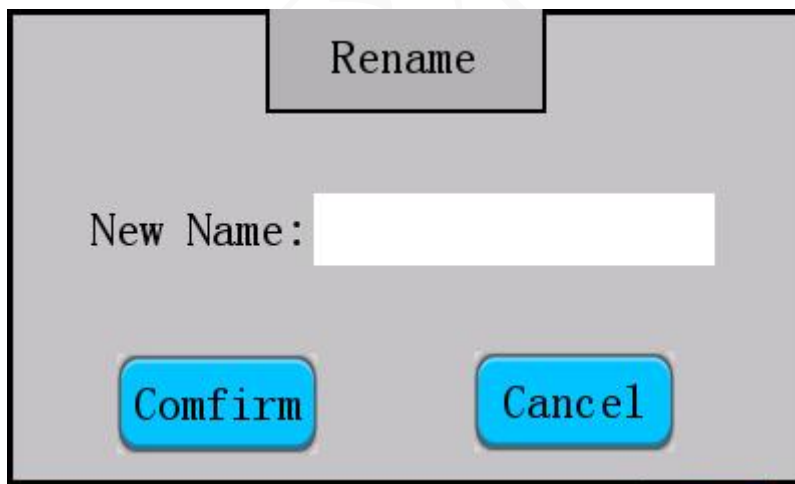

Figure 5-3 Rename File Interface

Delete: Cursor selects the file to be deleted and clicks the Delete button.

Copy: Click the Copy button to bring up the following pop-up box, enter the number of the copied file and the number of the copied file and click OK to save it.

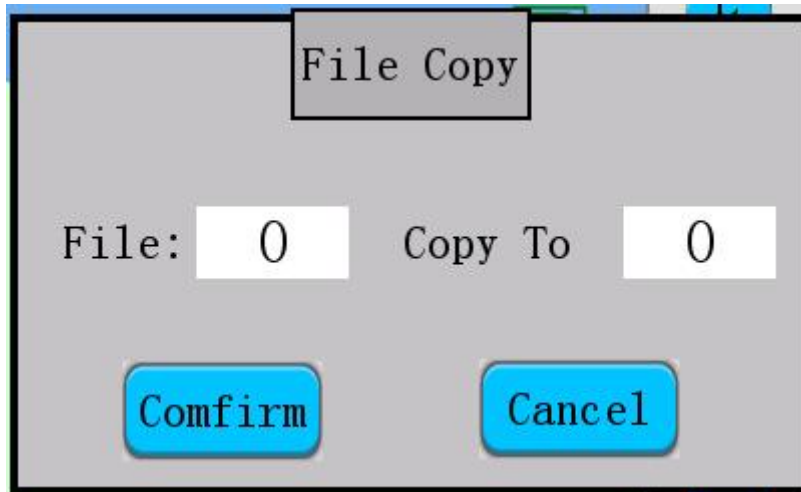

Figure 5-4 Copy File Interface

Chapter 6 IO Monitor

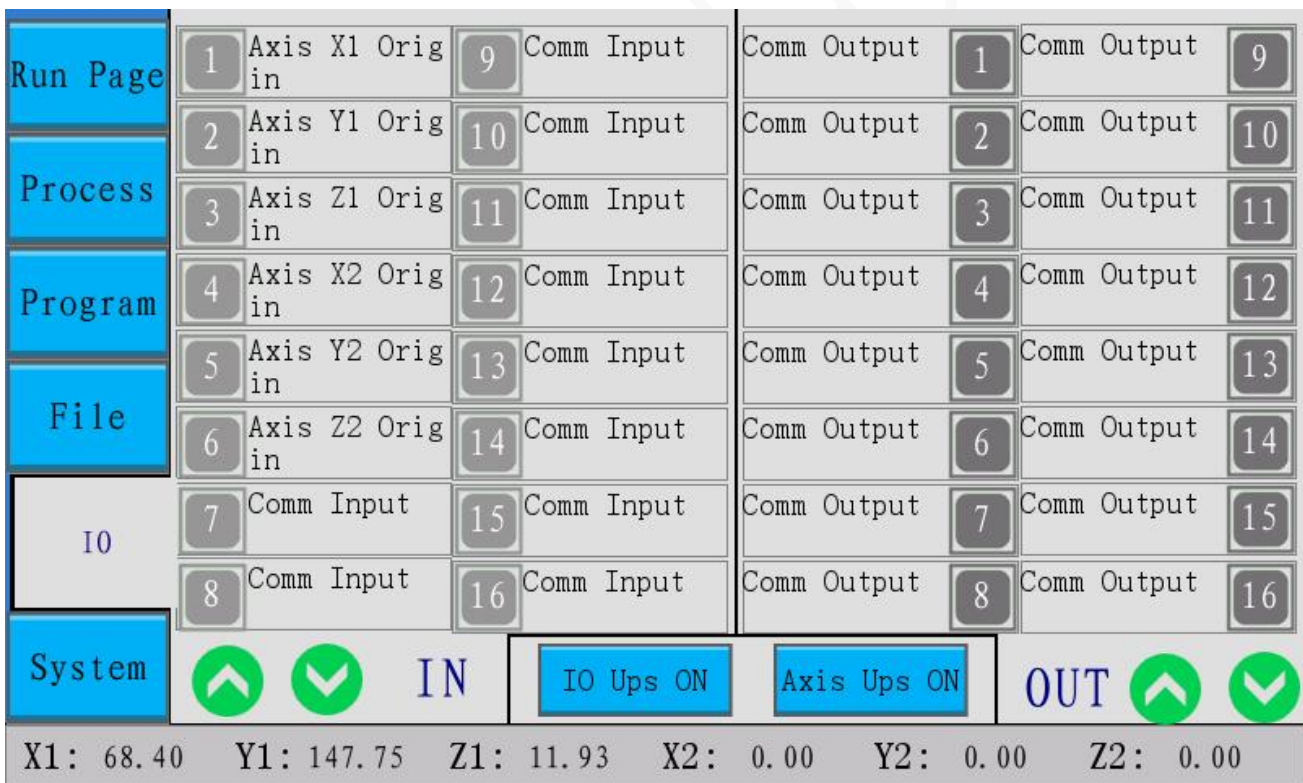

Figure 6-1 IO Monitor Interface

01-06 of 'General Input' are the home signals of X1, Y1, Z1, X2, Y2, Z2 axes respectively, and the value is '1' when there is an input signal, and the value is '0' when there is no input signal. The value is '1' if there is an input signal and '0' if there is no input signal.

07-08 of 'General Input' are programmable quick inputs, the value is '1' if there is an input signal and '0' if there is no input signal.

09-32 of 'General Input' are programmable normal inputs, the value is '1' when there is an input signal and '0' when there is no input signal.

The 01-24 points of 'General Output' can be tested, when the input value is '1', the corresponding output light is on, then the test port is normal, and vice versa is not normal. If the corresponding output light is off when the input value is '0', the test port is normal, and vice versa.

IO pop-up window ON/OFF:

Click IO pop-up window ON to pop-up IO small screen for IO monitoring or control, click IO pop-up window OFF to close the pop-up window.

Axis Movement ON/OFF:

Click Axis Move ON to open the Axis Move small panel, and click OFF to put it away for convenient device debugging.

Click on the up and down green arrows next to the IO to change the IO ports for monitoring or control.

Chapter 7 System parameters

7.1 Axis parameter setting

Axial Parameter						
Axis	X1	Y1	Z1	X2	Y2	Z2
Pulse Num	6400	6400	6400	6400	6400	6400
Pitch (mm)	52.00	52.00	52.00	52.00	52.00	52.00
Travel (mm)	300.00	300.00	100.00	300.00	300.00	100.00
Offset (mm)	0.00	0.00	0.00	0.00	0.00	0.00
Type	Shield	Shield	Shield	Shield	Shield	Shield
Priority	L	L	H	L	L	H
<input type="button" value="Save"/>			<input type="button" value="Back"/>			

Figure 7-1-1 Axis Parameter Interface

Number of pulses: is the number of pulses per revolution of the drive motor, i.e. the motor's fine fraction.

Pitch: is the distance travelled by the motor per revolution, i.e. the circumference of the pulley or the pitch of the screw.

Length of travel: the longest distance the shaft can move.

Origin Offset: the origin offset value can be 0 or positive or negative, i.e., the origin position is captured and then offset by a set value as the 0 coordinate.

Home type:

Normally closed/normally open: when the motor axis is not triggered to the origin, the origin capture sensor output is low or the micro switch is the sensor is closed state for normally closed, and vice versa for normally open.

Shielded: If shielded is selected, the axis does not use the home return or limit function.

Home Priority: Set the order of home return, the order of home return is as follows: High > Medium > Low, the same priority can be set to return home at the same time. The default is high priority for Z-axis and low priority for XY-axis.

Set Right/Left Machine Parameters: Click to switch between the right and left machine parameter setting page.

7.2 Batch parameter setting

For details, see Electric Batch Parameter Settings in Chapter 3 - Group Parameters.

7.3 Machine Structure Setting

The screenshot shows a software interface for machine structure settings. At the top, there is a title bar labeled 'Structure' and a red tip that reads 'Tip:Set 0 Disable Function'. Below this, the interface is organized into several sections. On the left, there is a 'Feed Way' dropdown menu set to 'All Blow'. Below it is a 'Move Way' section with two sub-dropdowns: 'Left' and 'Right', both set to 'Default'. Further down are 'Group Para' (set to 'Combined') and 'Parabola' (set to 'Enable'). On the right side, there is a 'Structure' dropdown menu set to 'Dual Gantry', followed by '485 Buad Rate' (set to '9600'), 'Smart Batch' (set to 'WeiHua'), 'Run Start Line' (set to 'First'), and 'Language' (set to 'English'). At the bottom of the interface, there are two large buttons: 'Save' and 'Back'.

Figure 7-3-1 Machine Structure Setting Interface

Feeding method: 1. left and right suction type; 2. left and right blowing type; 3. left suction and right blowing; 4. right suction and left blowing.

Left machine movement mode (XY axis forward/X axis reverse/Y axis reverse/XY axis reverse): Select according to the actual application scenario.

Right machine travelling mode (XY-axis forward/X-axis reverse/Y-axis reverse/XY-axis reverse): select according to the actual application scenario.

Machining group parameter: left and right independent or left and right bound can be selected. That is, whether the group parameters of the left and right machines are the same.

Motion Parabola: Click to enable that the machine will move in a parabolic way to improve efficiency.

Machine axes structure: 1. Double three-axis platform type; 2. Double three-axis gantry type; 3. Left platform and right gantry; 4. Left gantry and right platform; 5. Four-axis double platform; 6. Six-axis front and back collaboration.

Description:

- 1. Dual 3-axis platform:** The board is used as two independent platform 3-axis cards, while the two 3-axis cards have no direct business intersection.

Axis correspondence					
Axis1	Axis2	Axis3	Axis4	Axis5	Axis6
X1	Y1	Z1	X2	Y2	Z2

The origin signals are: X1-axis input 1 Y1-axis input 2 Z1-axis input 3 X2-axis input 4 Y2-axis input 5 Z2-axis input 6.

- 2. Dual Tri-Axis Gantry:** The boards are used as two independent Gantry Tri-Axis cards, while the two Tri-Axis cards have no direct business intersection.

Axis correspondence					
Axis1	Axis2	Axis3	Axis4	Axis5	Axis6
X1	Y1	Z1	X2	Y2	Z2

The origin signals are: X1-axis input 1 Y1-axis input 2 Z1-axis input 3 X2-axis input 4 Y2-axis input 5 Z2-axis input 6.

3. Left platform, right gantry, left gantry, right platform: the boards are used as two independent 3-axis cards, the type of platform gantry hybrid, at the same time the two 3-axis cards have no direct business intersection.

Axis correspondence					
Axis1	Axis2	Axis3	Axis4	Axis5	Axis6
X1	Y1	Z1	X2	Y2	Z2

The origin signals are: X1-axis input 1 Y1-axis input 2 Z1-axis input 3 X2-axis input 4 Y2-axis input 5 Z2-axis input 6.

3.6-axis front and rear collaborative: the board is used as a front and rear double Y platform type 6-axis, while the front and rear position collaborative machining logic.

Axis correspondence					
Axis1	Axis2	Axis3	Axis4	Axis5	Axis6
X1	Y1	Z1	X2	Y2	Z2

The origin signals are: X1-axis input 1 Y1-axis input 2 Z1-axis input 3 X2-axis input 4 Y2-axis input 5 Z2-axis input 6.

5.Quad-axis dual Y-platform: The board is used as a dual Y-platform quad-axis, with logical overlap between the left and right Y-platforms.

Axis correspondence					
Axis1	Axis2	Axis3	Axis4	Axis5	Axis6
X	Y1	Z	Y2	Spare	Spare

The origin signals are: X-axis input 1 Y1-axis input 2 Z-axis input 3 Y2-axis input 4 .

6.Four-axis dual-Y platform with rotary: the board is used as a dual-Y platform and a rotary axis is hung on each Y.

The origin signals are: X-axis input 1 Y1-axis input 2 Z-axis input 3 Y1 rotary axis input 4 Y2-axis input 5 Y2 rotary axis input 6.

Axis correspondence					
Axis1	Axis2	Axis3	Axis4	Axis5	Axis6
X	Y1	Z	Y1 axis of rotation	Y2	Y2 axis of rotation

Six-axis collaboration modes: 1. Sequence priority, running strictly in accordance with the machining sequence; 2. Efficiency priority, running in a non-fixed sequence. Customers can choose according to the actual application scenarios. (Only for six-axis collaboration structure)

Smart electric batch: Select the intelligent electric batch brand. At present, it supports Yakotec, Heichao , Hechuan ,SV, jiemeikang, WeiDe and other servo brands.

485 baud rate: Baud rate of intelligent electric batch communication.

Running start position: There are two options for setting the starting position of operation: "first row" or "current line". The setting of the current line can be set in "current machining position" in the machining operation interface.

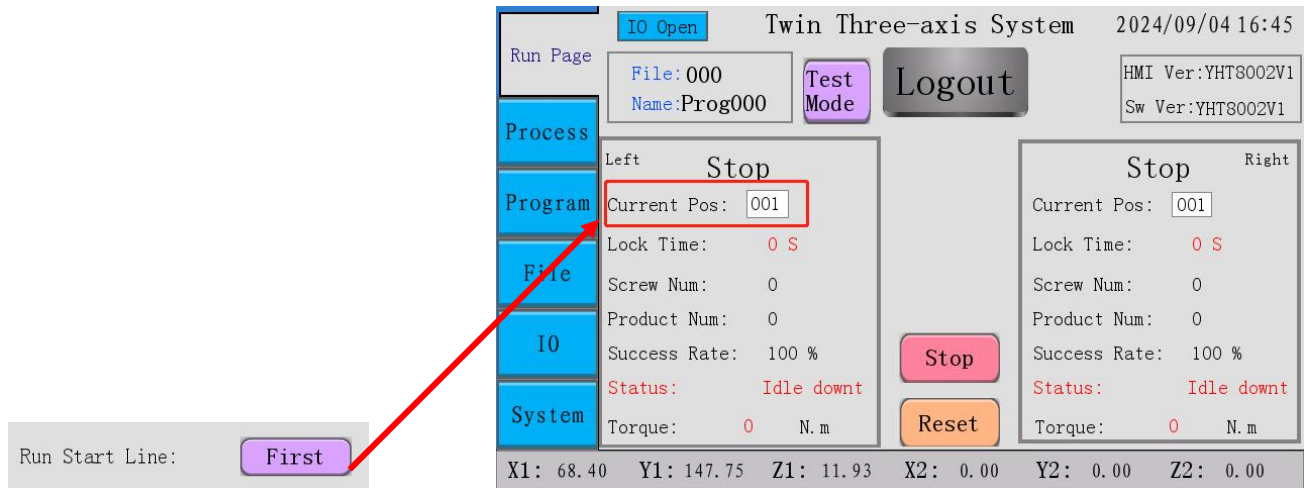

Figure 7-3-2 Current Machining Position Details

7.4 Workpiece Inspection Function Setting

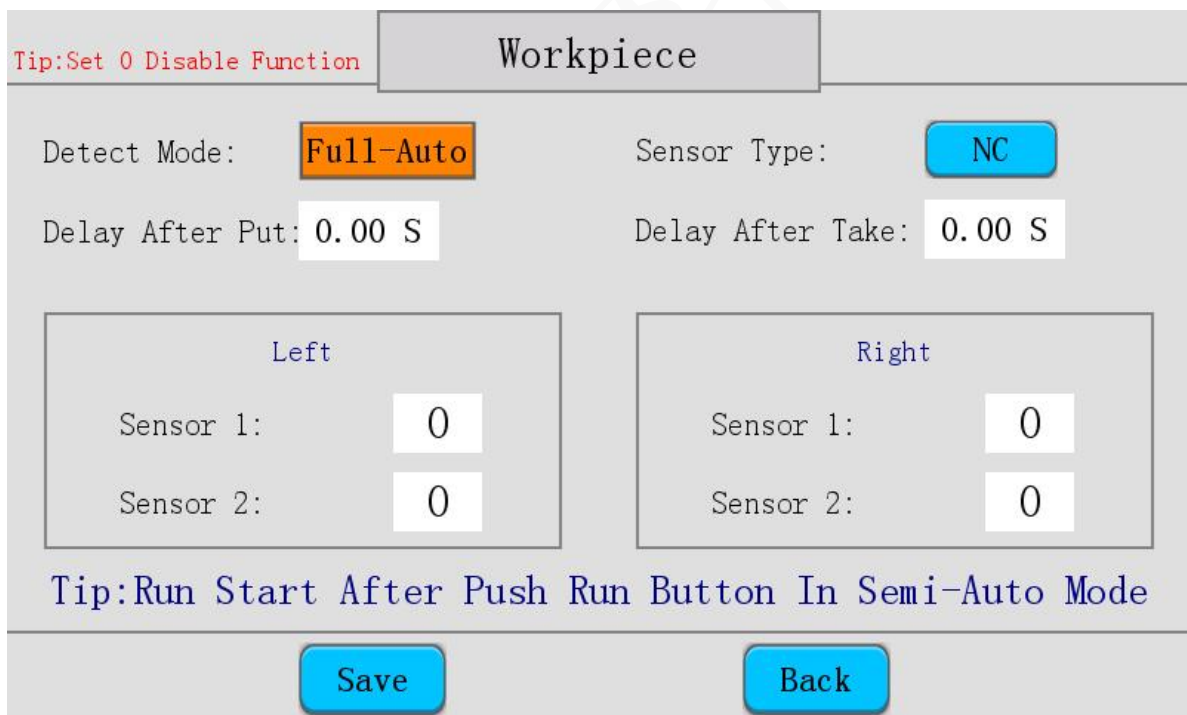

Figure 7-4-1 Workpiece Inspection Setting Interface

Workpiece detection modes:

- a) Automatic: it runs automatically after detecting the workpiece is put in place;
- b) Semi-automatic: the button must be pressed to run after the workpiece is detected and placed.

Sensor signal type: workpiece detection sensor signal type.

Delay time after product put away: the workpiece detection sensor detects the workpiece put away and then delays for a set time before starting the operation.

Delay after product removal: After the workpiece has been processed, delay for a set time and return to the 0 position.

Sensor No.1/2 (input): Input port of workpiece detection sensor.

7.5 Product Clamping Function Setting



Figure 7-5-1 Product Clamp Setting Interface

Clamping cylinder signal type: Product clamping in place sensor signal type.

Status when returning to original: hold/release/clamp.

Hold: The current state of the clamping cylinder is not changed when returning to the original state.

Release: It means to release the clamping cylinder when returning to the original state.

Clamping: The clamping cylinder is clamped when returning to the original position.

Status at positioning: Hold/release/clamp can be set.

Cylinder 1 action time: Clamping cylinder 1 action time.

Cylinder 2 action time: Clamping cylinder 2 action time.

Clamping cylinder 1/2 (output): Clamping cylinder control signal output port.

Clamping in place 1/2 (input): Clamping in place sensor signal input port.

7.6 Product Removal Function Setting

Left		Removal Product		Right	
Manual Button:	0	Mode:	Disable	Manual Button:	0
H-Cylinder Port:	0	Take Away Pos:	Both 0	H-Cylinder Port:	0
H-Cylinder Reach:	0	H-Cylinder Delay:	0.00 S	H-Cylinder Reach:	0
V-Cylinder Port:	0	V-Cylinder Delay:	0.00 S	V-Cylinder Port:	0
V-Cylinder Reach:	0	Suck Detect Time:	0.00 S	V-Cylinder Reach:	0
Suction Cylinder:	0			Suction Cylinder:	0
Suction Detect:	0			Suction Detect:	0

Buttons: Save, Back

Figure 7-6-1 Product Pickup Setting Screen

Function modes:

a) Pneumatic Cylinder Pickup: Use the pneumatic arm to pick up the product automatically after the product has been processed.

b) Manual pickup: the product will be picked up manually after the product has been processed.

Position of product removal: the product will be automatically moved to the set position to be removed after processing.

Horizontal cylinder action time (s): Horizontal displacement cylinder action time.

Vertical cylinder action time (s): Vertical displacement cylinder action time.

Suction detection time (s): Successful detection of adsorption, when no successful adsorption signal is received within the set time, the alarm will be 'Suction detection timeout'.

Manual take away button (input): manual take away mode: after receiving this signal, it means that the product has been taken away and the machine returns to 0 position.

Horizontal displacement cylinder (output): horizontal displacement cylinder control signal output port.

Horizontal cylinder in place (input): Horizontal displacement cylinder launch detection sensor signal input port.

Vertical displacement cylinder (output): vertical displacement cylinder control signal output port.

Vertical cylinder in place (input): Vertical displacement cylinder push-out detection sensor signal input port.

Suction product cylinder (output): Suction product control signal output port.

Suction product detection (input): Successful adsorption detection sensor signal input port.

7.7 Speed parameter setting

Speed Parameter			
Start Speed (mm/s) :	5.0	Manual Fast (mm/s) :	80.0
Stop Speed (mm/s) :	5.0	Manual Medium (mm/s) :	40.0
Max Speed Of X (mm/s) :	1200.0	Manual Slow (mm/s) :	1.0
Max Speed Of Y (mm/s) :	1200.0	Locate Speed (mm/s) :	300.0
Max Speed Of Z (mm/s) :	1200.0	Reset Speed (mm/s) :	80.0
		Capture Speed (mm/s) :	30.0

Figure 7-7-1 Speed Parameter Setting Screen

Start speed: Initial speed range 0-30 when the motor starts, recommended 5.

Stop Speed: the end speed range when the motor stops 0-30, recommended 5.

Maximum Speed: Set the maximum value of the speed of each axis allowed in the user's programming, which prevents the user from setting a speed greater than that required by the machine's design and causing a lost step.

Teach fast/medium/slow speed settings: manual movement speed is divided into fast, medium and slow three speeds, press the 'speed' key can be switched cyclically. Usually, the high speed is set to 80mm/s, the medium speed is set to 40mm/s and the low speed is set to 1mm/s;

Teaching positioning speed: the speed used when the machine moves to the corresponding position when the positioning button is pressed.

Back to home speed: the speed at which the motor axis moves from the direction that is not the home capture direction to the capture direction, this speed can be higher, the general setting range is 50-150mm/s.

Back to home capture speed: the speed at which the motor axis moves to trigger the home signal, in order to improve accuracy, this speed should not be too high, the general setting range is 20-60mm/s.

7.8 Acceleration parameter setting

In practice, the manual movement acceleration can be set smaller, generally between 100-500, the manual movement acceleration can be set smaller in the manual have a clear start acceleration process, in the movement of high speed is easier to achieve a small distance to move, taking into account the speed and small distance to move.

The control system supports asymmetric acceleration and deceleration, start acceleration and stop acceleration can be set to different values, the actual application will generally set the stop acceleration than the start acceleration. Acceleration size should be set according to the motor's driving ability, load size, mechanical properties and other comprehensive consideration, in order not to lose steps, vibration is not too large as the standard.

ACC Parameter		Unit:mm/s*s	
Start ACC Of X:	6000	Stop ACC Of X:	6000
Start ACC Of Y:	6000	Stop ACC Of Y:	6000
Start ACC Of Z:	4000	Stop ACC Of Z:	4000
Start ACC Of Manual:	400	Stop ACC Of Manual:	400
Estop ACC:	8000		
Save		Back	

Figure 7-8-1 Acceleration Parameter Setting Interface

7.9 Machine button setting

Button Port		Tip:Set 0 Disable Function	
Stop:	0	Run/Pause (ALL) :	0
Run/Pause (L) :	0	Run/Pause (R) :	0
Batch/Retry (L) :	0	Batch/Retry (R) :	0
Reset:	0	Estop:	0
Single Step:	0	Estop 2:	0
Manual Adjust:	0	Estop Type:	NO
Estop 2 Only Is Valid On Dual Three Axis			
Save		Back	

Figure 7-9-1 Machine Button Port Setting Screen

Stop: Stop button input port.

Total Run/Pause: Run/Pause button input port.

Left machine Run/Pause: Left machine Run/Pause button input port.

Right machine Run/Pause: Left machine Run/Pause button input port.

Left machine Electric Approval/Repeat: Left machine Electric Approval/Repeat button input port.

RIGHT MACHINE GRADE/REPEAT: Right machine GRADE/REPEAT button input port.

Home/Reset: Home/Reset button input.

Emergency Stop: Emergency stop button input port.

Single Step: Single step button input port.

Emergency Stop Signal Type: Emergency stop button signal type.

Manual calibration: Manual calibration button input port.

7.10 Grille & Tri-colour Light Setting

Tip:Set 0 Disable Function		Raster&Lights			
Raster:	Disable	Trigger Mode:	Continue	Delay Restore(s):	0.000
Left		Right			
Type:	NO	Type:	NO		
Raster Signal#1:	0	Raster Signal#1:	0		
Raster Signal#2:	0	Raster Signal#2:	0		
Run Light:	0	Run Light:	0		
Alarm Light:	0	Alarm Light:	0		
Idle Light:	0	Idle Light:	0		
Save		Back			

Figure 7-10-1 Raster & Indicator Port Setting Interface

Grating protection: need to be set to open before use, click to switch on or off.

Grating Trigger Mode: In the process of screwdriving, in order to prevent crashing objects and injuring people, in the process of running or returning to the home position, when the grating protection is sensed, it will respond according to the set grating trigger mode.

Description:

Pause: the device automatically enters the pause state after the grating alarm disappears.

Continue: The device automatically resumes the running state after the grating alarm disappears.

Stop: The device stops automatically after the grating alarm disappears.

Resume delay: After the grating alarm disappears, the device will enter the follow-up mode after a delay of the set time.

Grating signal type: set the grating signal type.

Grating Signal #1/#2 (Input): Set the grating input signal port.

Run indicator (left machine/right machine): Run indicator control signal output port.

Alarm indicator (left machine/right machine): Alarm indicator control signal output port.

Idle indicator (left machine/right machine): Idle indicator control signal output port.

7.11 Home function setting

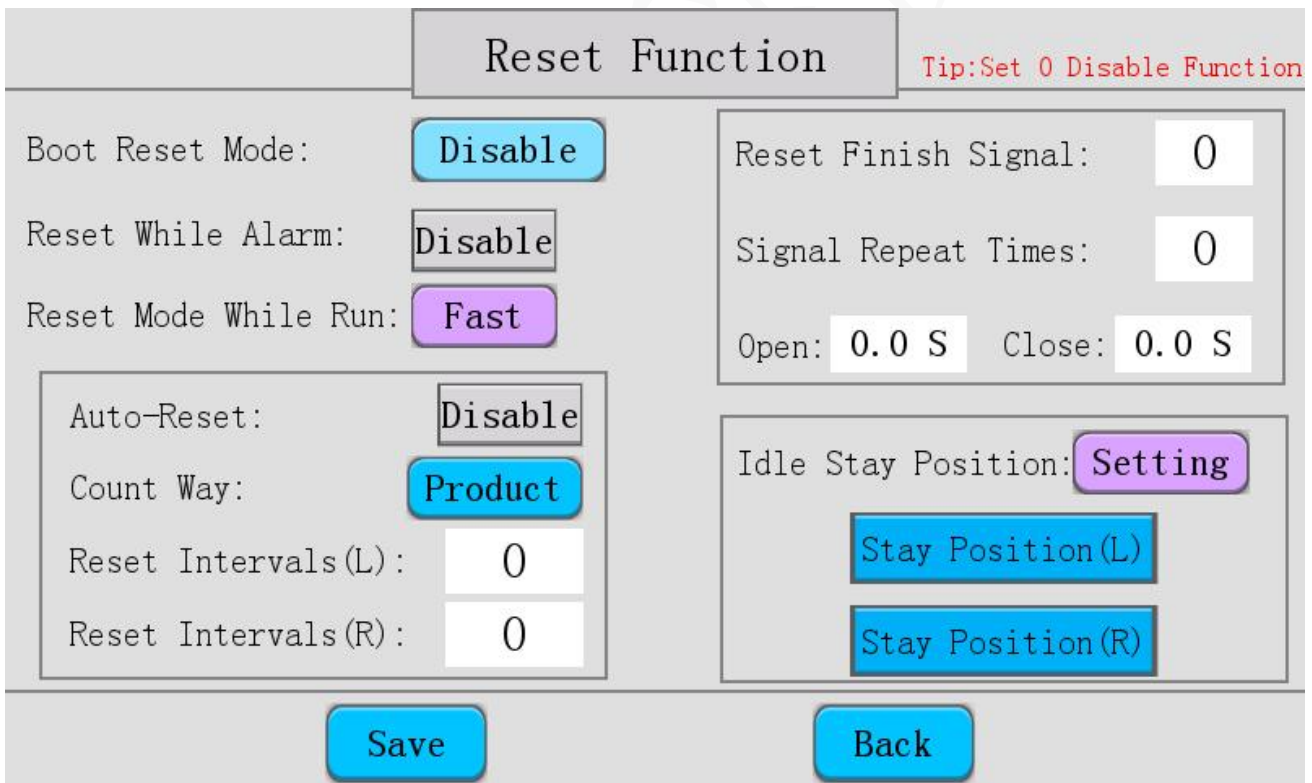

Figure 7-11-1 Home Return Related Function Setting Screen

Boot reset mode:

1、Prompt to reset: Prompt to return to the origin when powered on. Press the return to origin button to execute the return to origin action.

-
- 2、 **Automatic reset:** Directly execute the action of returning to the original point after power on.
- 3、 **Close:** Do not return to the origin: press the return to origin button after power on to perform the return to origin action.

Reset complete signal (output): After the equipment completes the action of returning to the original point, the completion signal is output from the set output port.

Open/Close(s): It indicates that the corresponding signal pin outputs a pulse signal after reset, and the signal type is shown in the figure below.

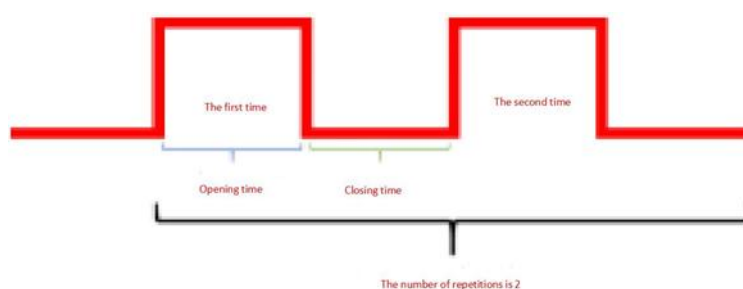

Figure 7-11-2 Pulse Signal

Automatic reset of processing alarm: If an alarm occurs during machining, it will automatically return to the original point.

Reset mode during operation: After machining the specified number of hole positions, the action of returning to the origin is automatically executed.

Reset if the running time(L): After the processing of the left machine reaches the set quantity, the reset action is automatically executed.

Reset if the running time(R): After the processing of the right machine reaches the set quantity, the reset action is automatically executed.

Rest position after resetting: After reset, the machine will automatically go to the set dwell position.

Zero: The machine stays at the origin position. **Set:** The machine stays at the origin position.

7.12 Other Function Setting

This interface allows you to set up drives, board upgrades, password management, and so on.

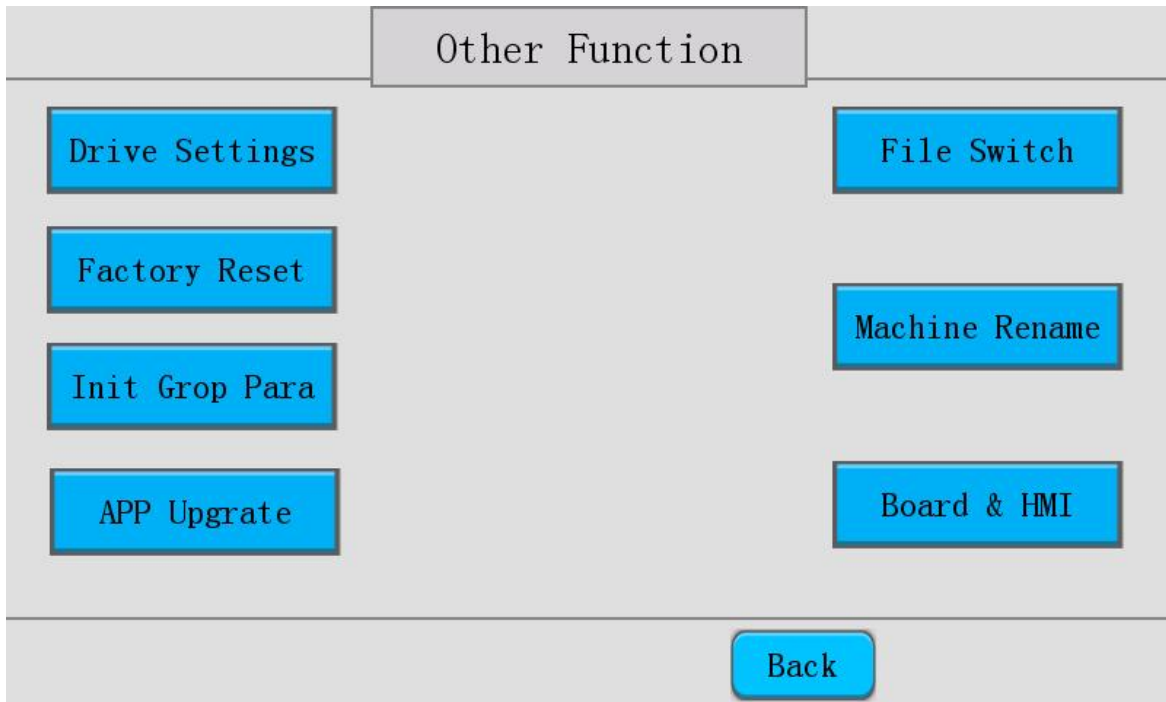

Figure 7-12-1 Home Return Related Other Functions Setting Screen

7.12.1 Drive-related settings

This screen allows you to make drive-related settings.

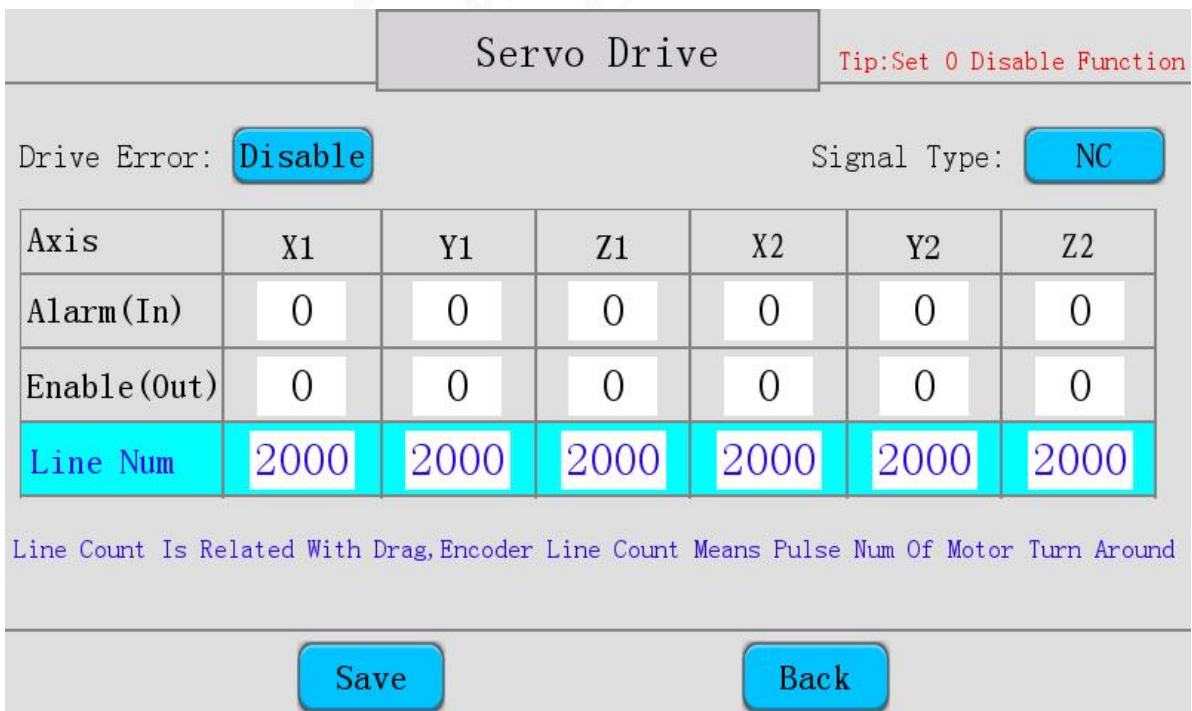

Figure 7-12-1-1 Driver Related Setting Interface

Drive Alarm: It should be set to 'Open' before using this function.

Alarm signal type: Set the drive alarm signal type, 1. normally open, 2. normally closed.

Setting drive alarm input port: Select according to the actual situation (except input port 1-6).

Alarm(In)	0	0	0	0	0	0
-----------	---	---	---	---	---	---

Figure 7-12-1-2 Driver Alarm Input Port Setting Interface

Drag and drop function related settings:

Step 1: Set the number of encoder lines in the following interface.

Line Num	2000	2000	2000	2000	2000	2000
----------	------	------	------	------	------	------

Figure 7-12-1-3 Encoder Line Number Setting Screen

Step 2: Setting the encoder enable ports (except 23 and 24 output ports).

Enable(Out)	0	0	0	0	0	0
-------------	---	---	---	---	---	---

Figure 7-12-1-4 Encoder Enable Port Setting Screen

Step 3: Turn on the drag and drop function. In the 'Teach Programming' interface, click the drag-and-drop button to display brown status, that is, to open the drag-and-drop function.

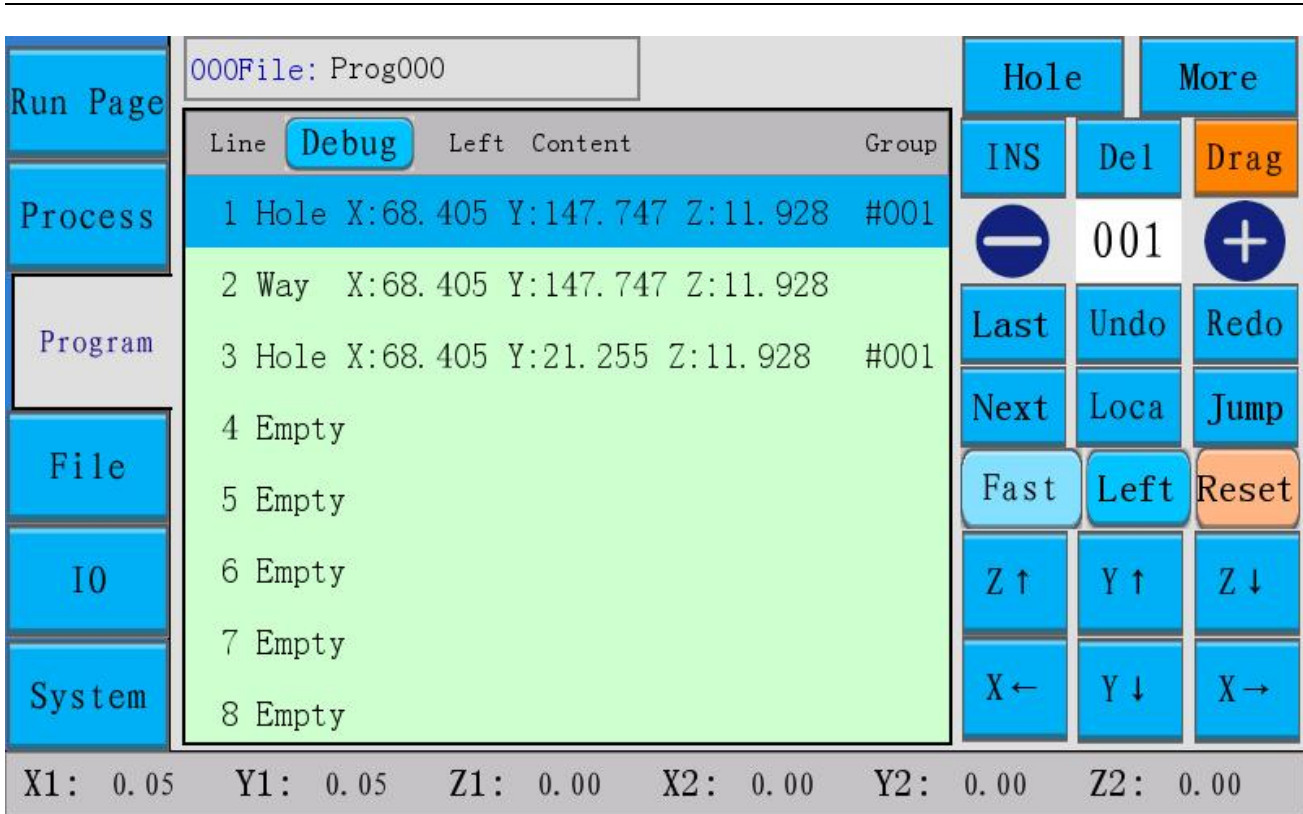

Figure 7-12-1-5 Drag and Drop Function User Interface

7.12.2 Restore Factory Setting

In this interface, click 'Restore Factory Settings' button to restore the factory default parameters.



Figure 7-12-2-1 Restore Factory Settings Confirmation Screen

7.12.3 Initialise processing parameters

Processing parameters are initialised After initialisation, all parameters are restored to the initial settings. Before initialisation, please remember the port number, each motor parameter, and other important parameters that have been set, and set them one by one after initialisation.



Figure 7-12-3-1 Confirmation interface of initialised machining parameters

7.12.4 Board application upgrade

The board can be upgraded in this interface with the following procedure.

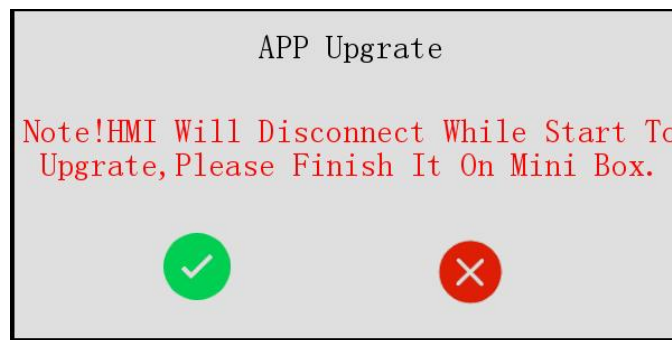

Figure 7-12-4-1 System Upgrade Confirmation Screen

Board application upgrade steps:

- Step 1:** Put the upgrade file XXXX.pkg file into the root directory of USB flash drive, and then plug the USB flash drive into the motherboard;
- Step 2:** Click the 'Upgrade Board Application' button to enter the upgrade prompt interface, click the 'Continue' button to disconnect the touch screen communication;
- Step 3:** Use the handheld programmer to upgrade the motherboard program, press the handheld (MinBOX Teaching Kit) 'up' or 'down' button to select the programme, press the 'screw hole' button for After the upgrade is completed, it will prompt the upgrade success (buzzer sounds);
- Step 4:** Repower the system after the upgrade is completed.

7.12.5 File Switching Setting

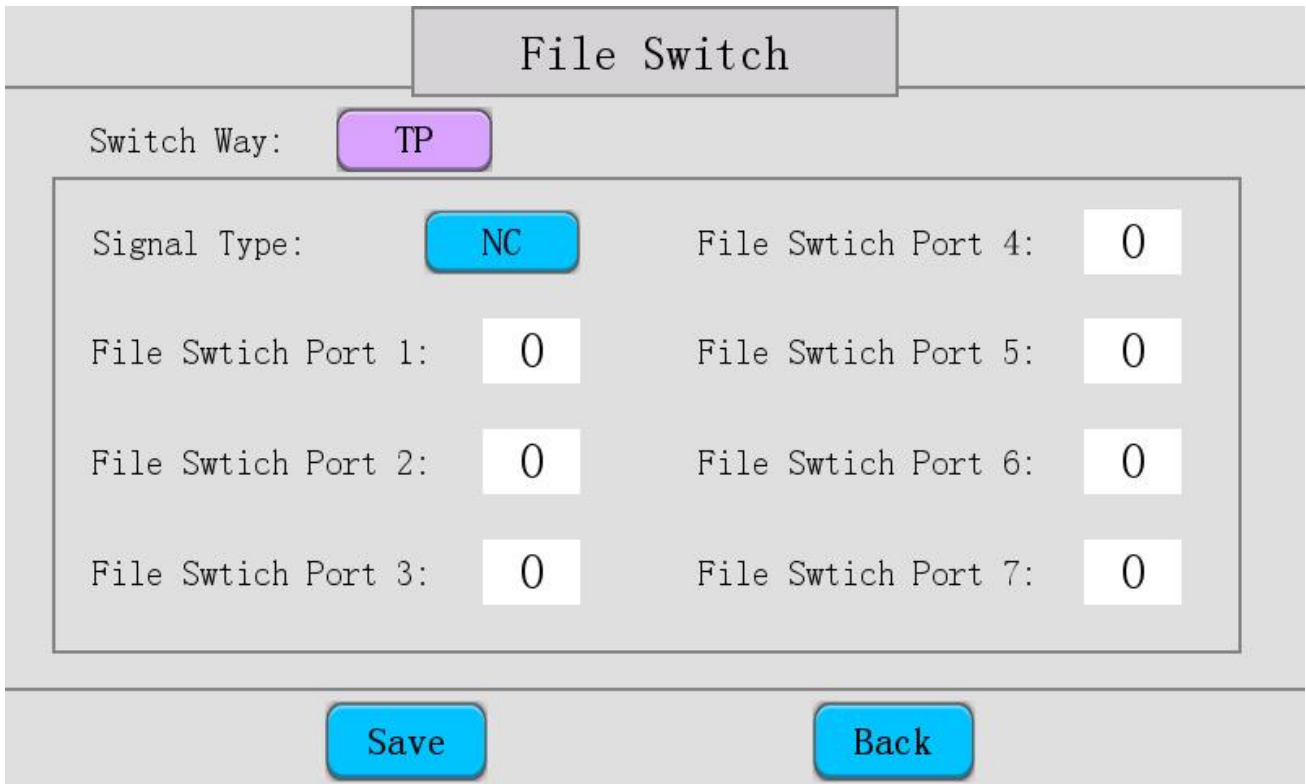

Figure 7-12-5-1 File Switch Settings Screen

File switching method: touch screen/external IO selectable

Touch panel: File switching using HMI

External IO: Port input control using external keys or PLC.

External IO input type: normally closed/normally open.

File switching port: The value corresponding to file switching port 1 is 1, the value corresponding to switching port 2 is 2, the value corresponding to switching port 3 is 4, the value corresponding to switching port 4 is 8, the value corresponding to switching port 5 is 16, the value corresponding to switching port 6 is 32, and the value corresponding to switching port 7 is 64 (e.g., to switch to the file No. 70, which means that the corresponding switching port input status is 0110001 (1-7: 0 means no signal input, 1 means signal input), i.e. $0 \times 1 + 1 \times 2 + 1 \times 4 + 0 \times 8 + 0 \times 16 + 0 \times 32 + 1 \times 64 = 70$)

7.12.6 Machine Name Editor

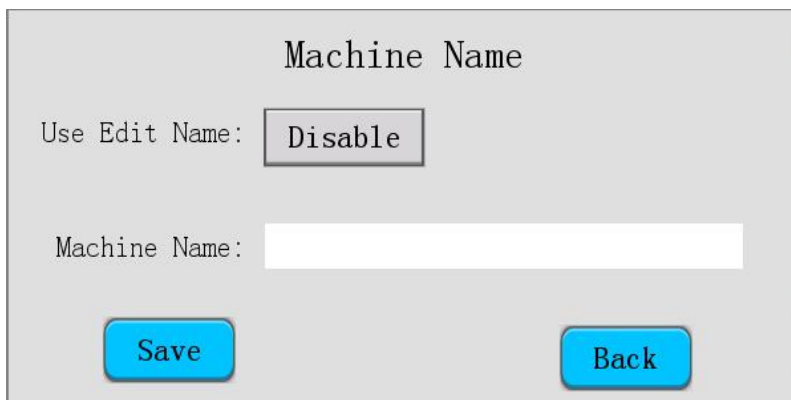

Figure 7-12-6-1 Device Name Edit Screen

Enable this feature to change the device display in the Run Home page, as shown in the following figure.

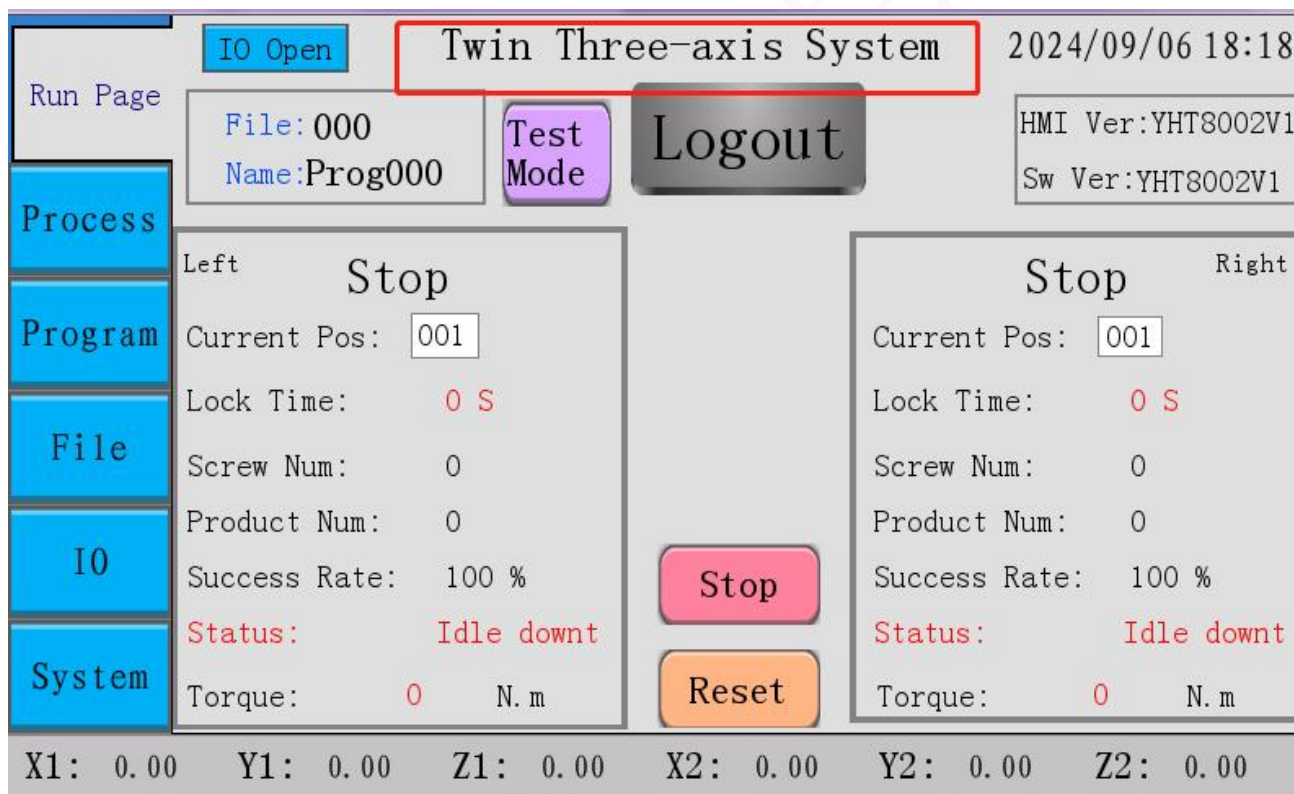

Figure 7-12-6-2 Device Name Display Screen

7.12.7 Password & HMI Management

The touch panel board clock setting, board password setting, trial period setting, and HMI password setting can be set under this interface.

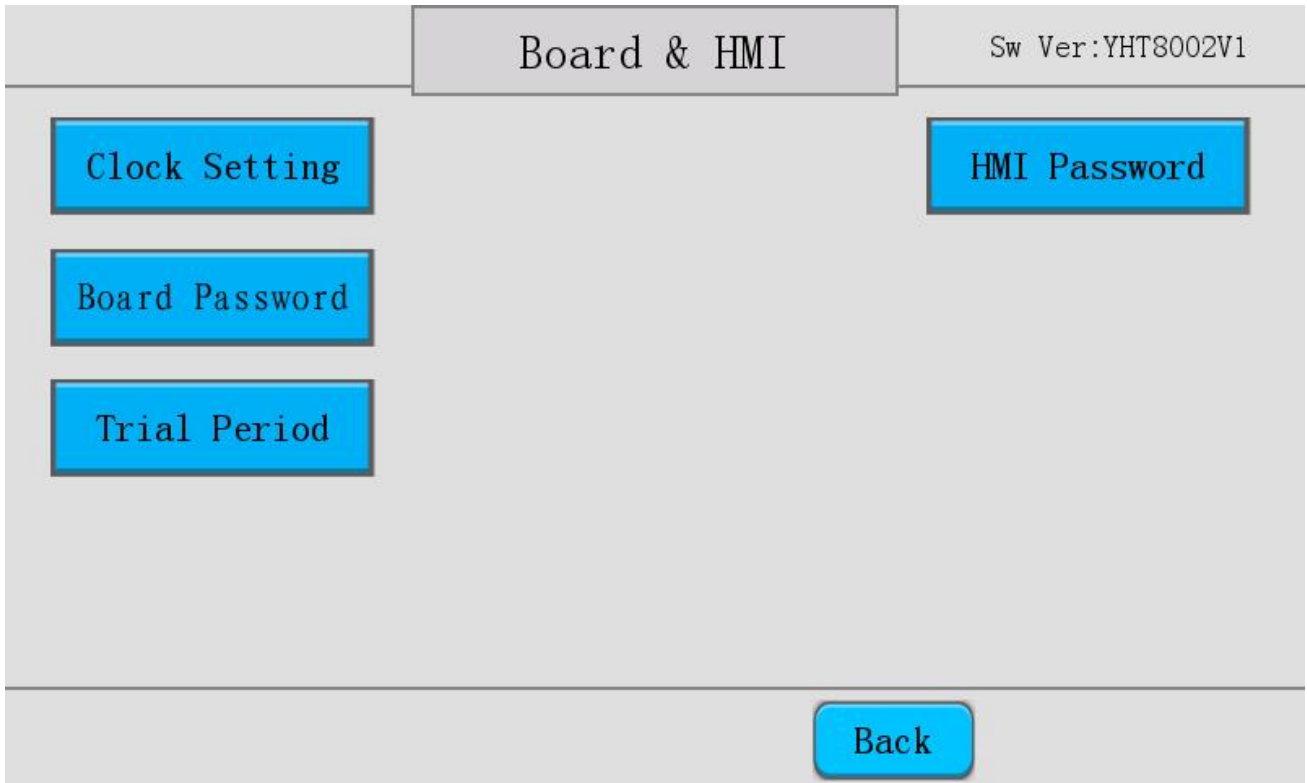

Figure 7-12-7-1 Password & HMI Setting Interface

Board Clock Setting

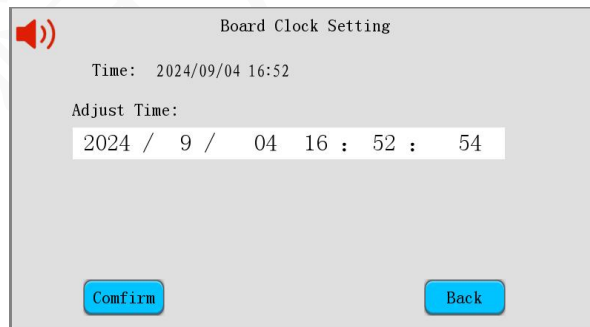

Figure 7-12-7-2 Board Clock Setting Interface

Board Password Setting

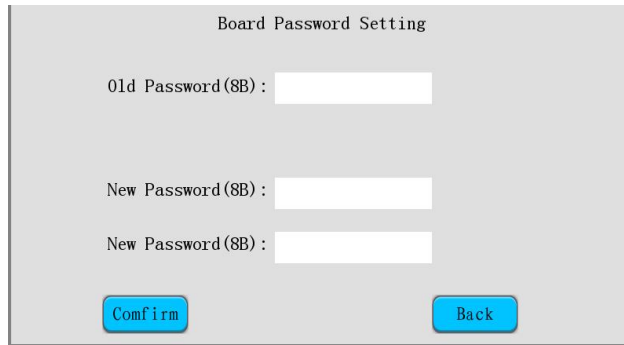

Figure 7-12-7-3 Board Password Setting Screen

HMI Password Setting

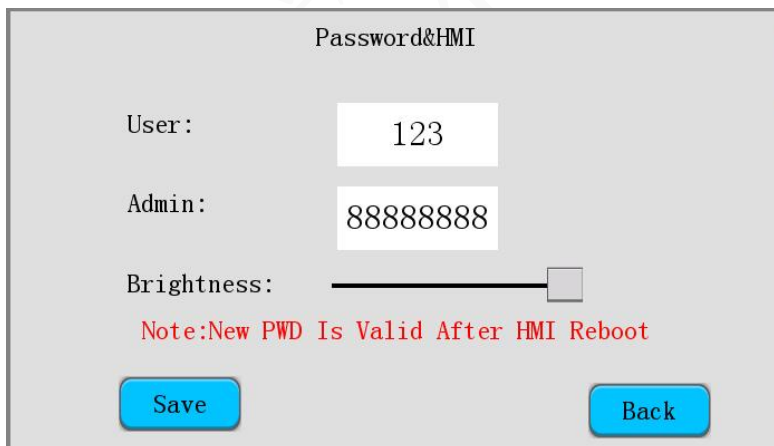

Figure 7-12-7-4 HMI Password Setting Interface

Probationary period setting

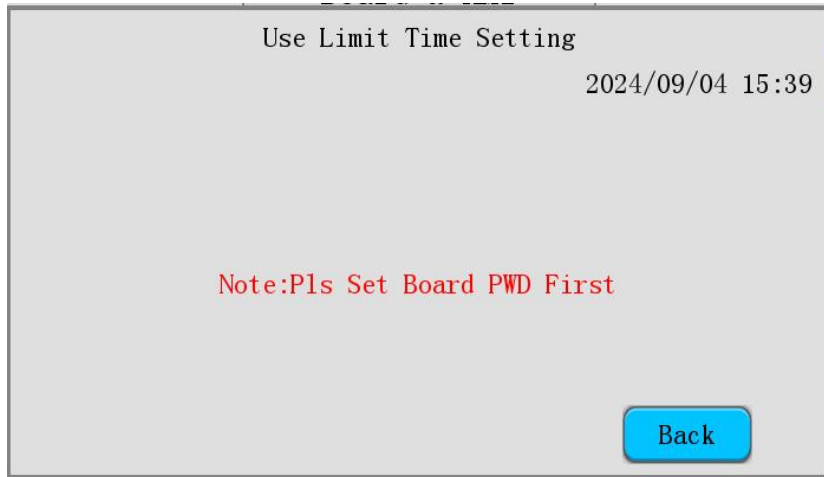

Figure 7-12-7-5 Trial Period Setting Screen

Please pay attention to the public number of HengkongControl Technology-->Product Centre-->Restriction Date Calculation-->Enter the password of the board as well as set the restriction time and click Generate, then enter the generated registration code into the box.